

UN_934 Hydraulic Home Lift

Planning data

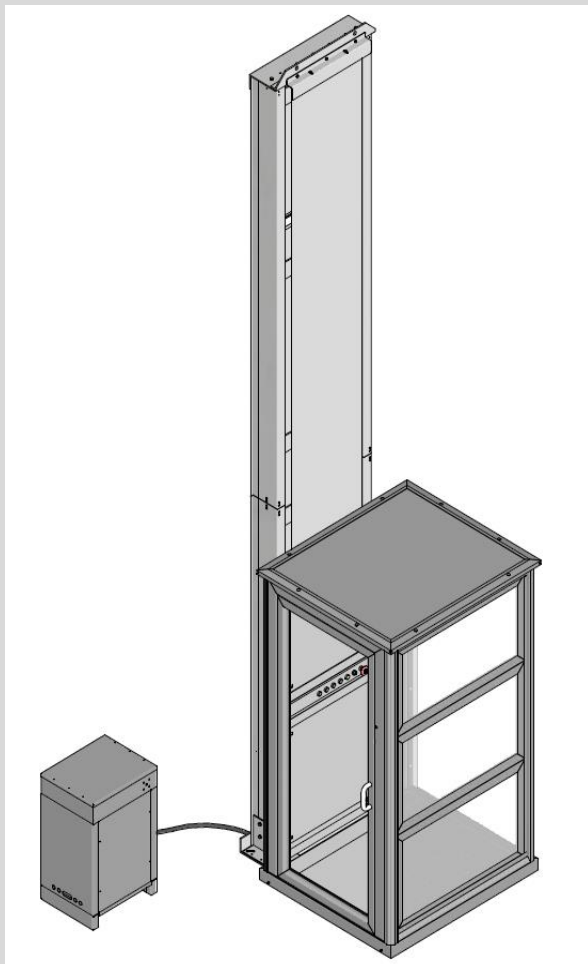

The UN_934 Home Lift is an innovative solution that elevates everyday living. It features a modern and customizable design, allowing homeowners to integrate it seamlessly into their living spaces. More than just a lift, it provides safe and effortless access to every level of your house, ensuring independence, comfort, and peace of mind.

Contact us

Unique Industry – Manthos Lift Solutions
Industrial Area of Larissa, Larissa, 41500, Greece

Phone: (+30) 2410-541558

Email: info@uniqueindustry.gr
sales@uniqueindustry.gr

Web: www.uniqueindustry.gr



UNIQUE
Manthos Lift Solutions

www.uniqueindustry.gr - info@uniqueindustry.gr

CONTENTS

| | | | |
|--|----|--|----|
| 1. Product Description | 3 | 10.3.2 Aluminium protective frames on 3 sides – “Π” shape..... | 20 |
| 2. Benefits | 4 | 10.4 Access - Ramp..... | 21 |
| 3. Safety | 4 | 11. Detailed Drawings | 22 |
| 4. Technical Description..... | 5 | 11.1 Cabin type A Entrance – Exit: Opposite sides..... | 22 |
| 5. Cabin Description..... | 6 | 11.2 Cabin type A Entrance – Exit: Same side | 23 |
| 5.1 Cabin types..... | 6 | 11.3 Cabin type A Entrance – Exit: Adjacent sides 90° | 24 |
| 5.2 Cabin standard equipment | 6 | 11.4 Cabin type A Entrance – Exit: Adjacent sides 90°..... | 25 |
| 5.3 Color of the lift | 6 | 11.5 Cabin type B Entrance – Exit: Opposite sides..... | 26 |
| 5.4 Cabin and cabin door lining | 6 | 11.6 Cabin type B Entrance – Exit: Same side | 27 |
| 5.5 Controls..... | 7 | 11.7 Cabin type B Entrance – Exit: Adjacent sides 90°..... | 28 |
| 5.6 Cabin doors | 7 | 11.8 Cabin type B Entrance – Exit: Adjacent sides 90° | 29 |
| 5.7 Closed cabin with double-leaf door (Optional)..... | 7 | 11.9 Cabin type C Entrance – Exit: Opposite sides..... | 30 |
| 5.8 Cabin dimensions..... | 8 | 11.10 Cabin type C Entrance – Exit: Same side | 31 |
| 6. Column | 9 | 11.11 Cabin type C Entrance – Exit: Adjacent sides 90° | 32 |
| 6.1 Column division (parts) per total travel..... | 9 | 11.12 Cabin type C Entrance – Exit: Adjacent sides 90° | 33 |
| 6.2 Column Support | 10 | 11.13 Cabin type D Entrance – Exit: Opposite sides | 34 |
| 6.2.1 Standard Column Support – Wall support..... | 10 | 11.14 Cabin type D Entrance – Exit: Same side | 35 |
| 6.2.2 Optional Column Support – Triangle support..... | 11 | 11.15 Cabin type D Entrance – Exit: Adjacent sides 90° | 36 |
| 7. Control Panel & Hydraulic Unit | 12 | 11.16 Cabin type D Entrance – Exit: Adjacent sides 90°..... | 37 |
| 8. Cabinet for the Control Panel & Hydraulic Unit..... | 13 | 12. 3d Visualisation | 38 |
| 9. Forces | 14 | 12.1 Closed cabin | 38 |
| 9.1 Forces at the pit base..... | 14 | 12.1.1 Entrance – Exit: Opposite sides, 2 stops..... | 38 |
| 9.2 Forces on the shaft wall | 15 | 12.1.2 Entrance – Exit: Opposite sides, 3 stops..... | 39 |
| 10. Optional Equipment..... | 16 | 12.1.3 Entrance – Exit: Same sides, 2 stops..... | 40 |
| 10.1 Level Doors..... | 16 | 12.1.4 Entrance – Exit: Same side, 3 stops..... | 41 |
| 10.1.1 Description & available options..... | 16 | 12.1.5 Entrance – Exit: Adjacent sides 90°, 2 stops..... | 42 |
| 10.1.2 Door height 1100mm..... | 17 | 12.2 Open Cabin | 43 |
| 10.1.3 Door height 2000mm..... | 18 | 12.2.1 Entrance – Exit: Opposite sides, 2 stops..... | 43 |
| 10.2 Aluminium protective barrier & level doors..... | 19 | 12.2.2 Entrance – Exit: Same side, 2 stops..... | 44 |
| 10.3 Aluminium protective frames on lower landing | 20 | 12.2.3 Entrance – Exit: Adjacent sides 90°, 2 stops..... | 45 |
| 10.3.1 Aluminium protective frames on 2 sides – “Γ” shape..... | 20 | | |

1. PRODUCT DESCRIPTION

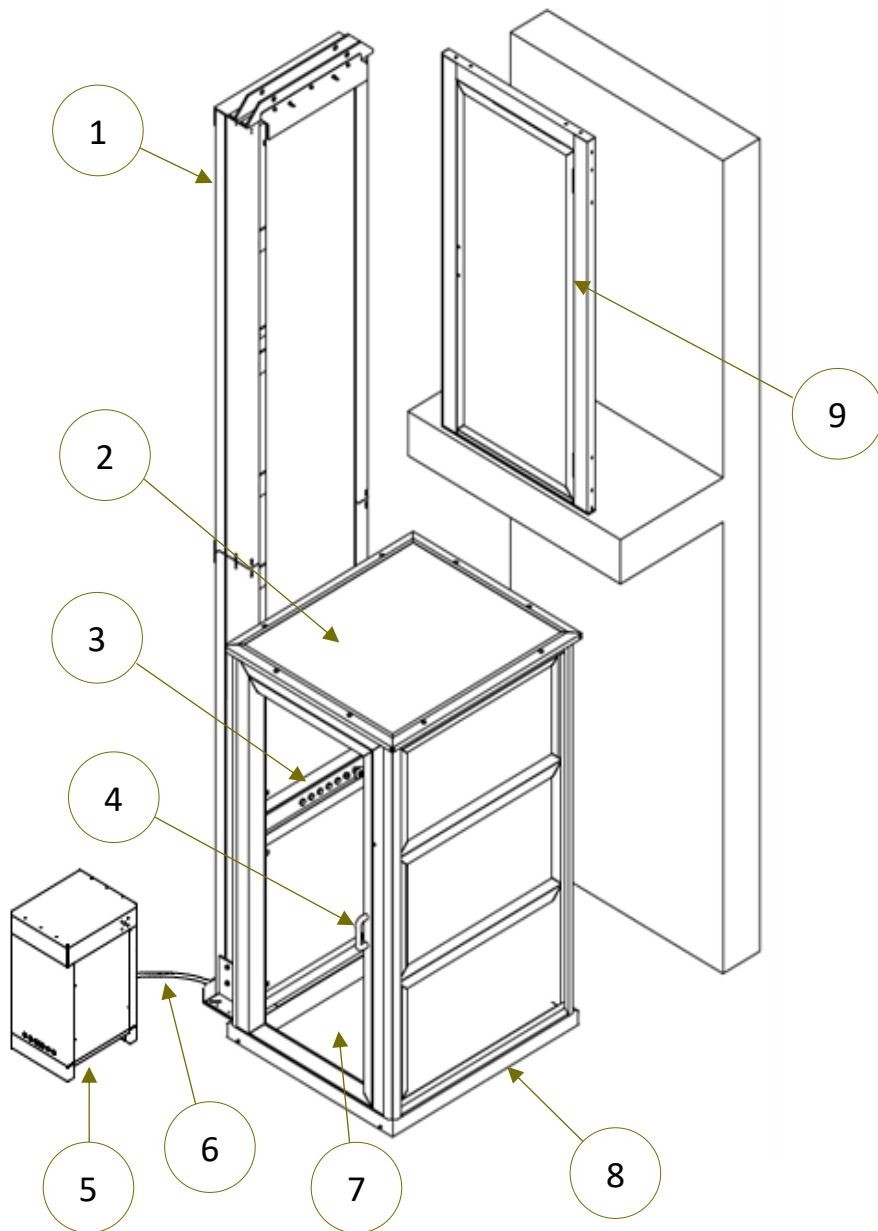

Information

- 1. Aluminium Column:** Lightweight and durable construction for easy installation.
- 2. Closed Cabin with Roof – Clear Height 2000mm:** Constructed from durable aluminum profiles, it features a protective roof with integrated LED lighting, while the side facing the lifting mechanism is fitted with blind panels.
- 3. Cabin Operation Panel (COP):** Ergonomically designed with clearly marked push-buttons for Up and Down, Emergency Stop, and a built-in alarm for added safety in emergencies.
- 4. Cabin Door Height 2000mm:** Full-height swing door for access at the bottom level. The door can be left or right hinged.
- 5. Cabinet:** It includes the hydraulic unit along with the control panel.
- 6. Rubber Hose:** Flexible tubing used to transport hydraulic fluid within the system.
- 7. Cabin Floor:** Anti-slip surface made of corrosion-resistant aluminum, ensuring safety and minimal wear over time.
- 8. Anti-crushing protective surface:** It is integrated under platform floor. Prevents entrapment by stopping the lift if an obstacle is detected underneath
- 9. Level Door:** It is installed at the upper stop to prevent accidental entry into the lift area when the platform is not at that level. The door is available in two height options: 1100 mm or 2000 mm.

2. BENEFITS

Our revolutionary "UN_934" provides access to all levels of your home and requires a minimum intervention in the existing building.

The installation of this lift does not require a shaft and it can be mounted directly to the building.

A minimal pit is needed.

It is suitable for both outdoor and indoor installations.

The installation procedure is easy and typically requires two to three days, ensuring a satisfied customer.

List of main advantages

- Small pit requirement
- Space – efficient lift solution
- Suitable for both outdoor and indoor installations
- Fast installation in 2 to 3 days

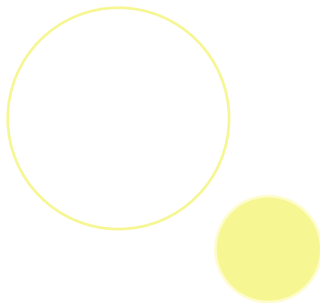

3. SAFETY

SAFETY IS OUR MAIN PRIORITY AND CORE VALUE

We have taken the proper measures to ensure the safety of the passengers in any given situation. That is why this lift model is equipped with safety gear in case the chain breaks. The entire system is supported by electromechanical locks and an anti-crushing protective surface is integrated under platform floor

We offer a 2-year standard warranty that can be optionally extended as per request from our customers.

Safety features

- Safety gear (in case the chain breaks)
- Emergency restraining device
- Terminal switches 24V
- Terminal stop switches 24V
- Electromechanical locks
- Anti-crushing protective surface integrated under platform floor
- Emergency STOP buttons
- Electronic engine control – PCB
- Battery operated evacuation system
- Hydraulic overload protection
- Safety valve at the bottom of the cylinder – Automatically stops the system in case of a broken hydraulic hose or tube.

4. TECHNICAL DESCRIPTION

General information

Loading capacity: Max 420kg (Depending on the size of the cabin & lining materials)

Max no of stops: 4 (5 stops, upon request)

Standard Platform Sizes: Type A, B, C and D

The lift is available in 4 standard sizes to suit different space needs.

Platform Clear Dimensions:

Type A: 820 x 1215 mm, Type B: 1020 x 1215 mm

Type C: 1120 x 1485 mm, Type D: 1120 x 1605 mm

Total Machine Dimensions:

Type A: 1246 x 1300 mm, Type B: 1446 x 1300 mm

Type C: 1546 x 1570 mm, Type D: 1546 x 1690 mm

Power Supply: 1.5kW, 220V (1-phase)

Current Operation: 16A

Main Required Fuse: 1 x fuse 16 A (slow) or circuit breaker 1 x 16 A (trigger characteristic K or C)

Maximum lifting height: 12000mm

○ **Open cabin:** 0 – 4m

○ **Closed cabin:** 0 – 12m

Speed: 0.12 – 0.14m/sec

Access height: 150mm

Headroom: 2100mm

Motor: 1,5kW

Metallic chain: 2X3/4' DW 8187 12B

Door configuration: Single access, open-through, 90° opening

Directives and standards: Machine Directive 2006/42/EC

Examination Certificate for compliance with European safety standards

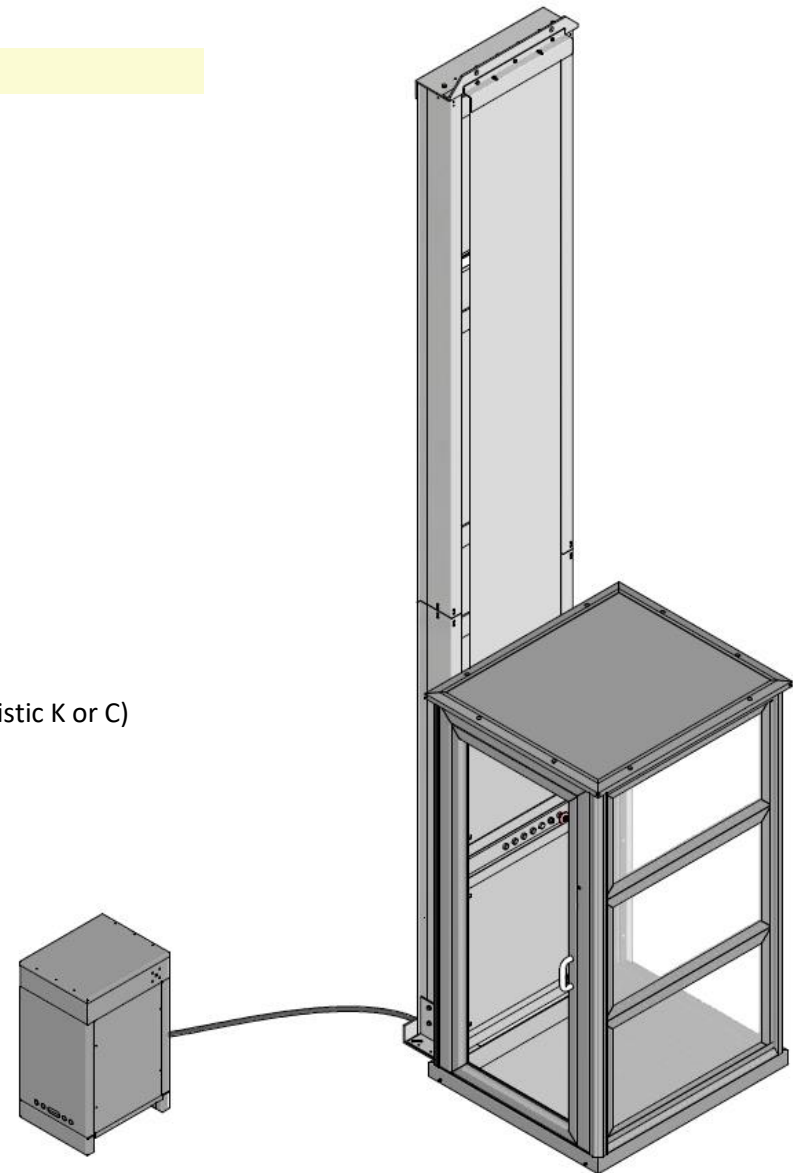

5. CABIN DESCRIPTION

5.1 Cabin types

The lift is available with two cabin configurations: a closed cabin with a height of 2000 mm and a roof for full enclosure, or an optional open cabin with a height of 1100 mm, recommended for travel distances under 4 m.

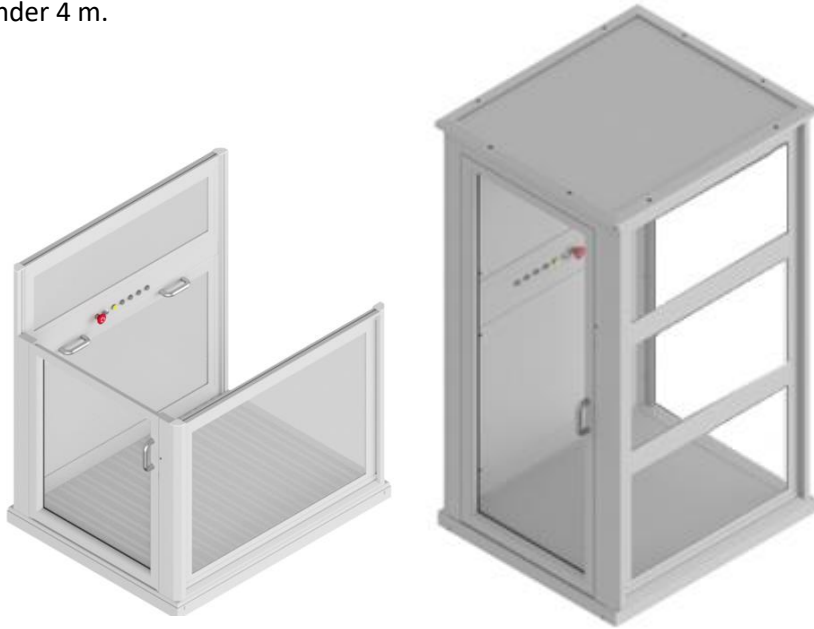

5.2 Cabin standard equipment

- The main frame of the cabin is made of aluminum profiles.
- Aluminium anti – slip surface is also fitted on the cabin floor.
- Handrail with integrated COP.
- The side of the cabin facing the building is equipped with photocells.
As an alternative option, it can be fitted with a double-leaf manual door that opens inward.
- Anti-crushing protective surface integrated under platform floor.

5.3 Color of the lift

The standard color of the lift is:
RAL 7040 NEOKEM AMMOS

<https://neokem.eu/en/ammos-collection-details/>



! Other options are available upon request

! Important Note

The cabin floor features a premium anodized finish, offering durability, a sleek appearance, and protection against wear.

5.4 Cabin and cabin door lining

The cabin and the cabin doors can be lined with either:

- Polycarbonate
- Triplex glass

! Important Note

The side that faces the mechanism is lined with blind panels as standard.

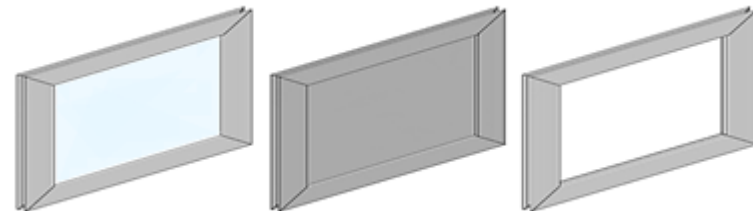

5.5 Controls

- LOP at the entrance with continuous pressure call button mounted on the wall.
- The COP inside the cabin includes floor buttons, key switch, alarm button and emergency stop.



5.6 Cabin doors

- Single door with left or right hinged according to your needs.
- Standard operation is semi-automatic.
- Optional double-leaf manual door that opens inward, in the case of the closed cabin.
- Lining according to your desire.

5.7 Closed cabin with double-leaf door (Optional)

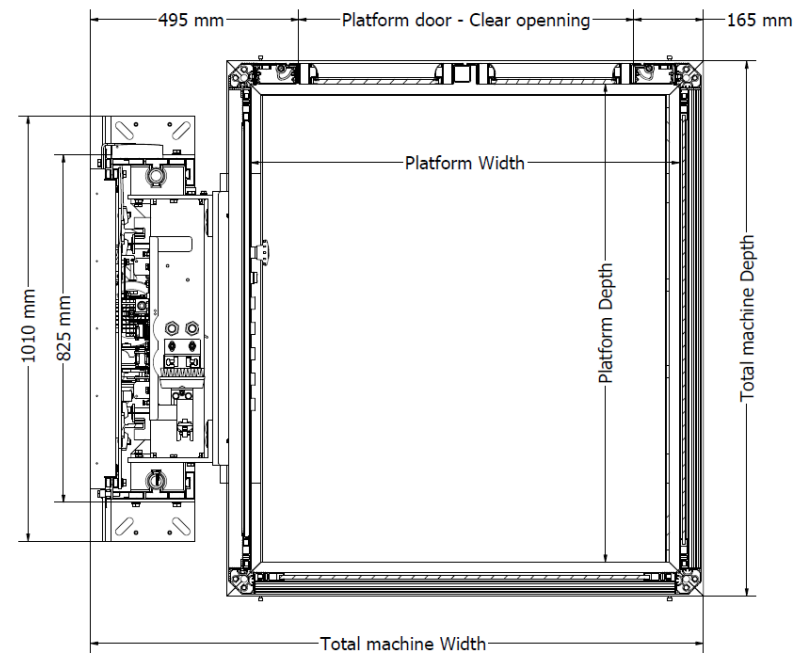
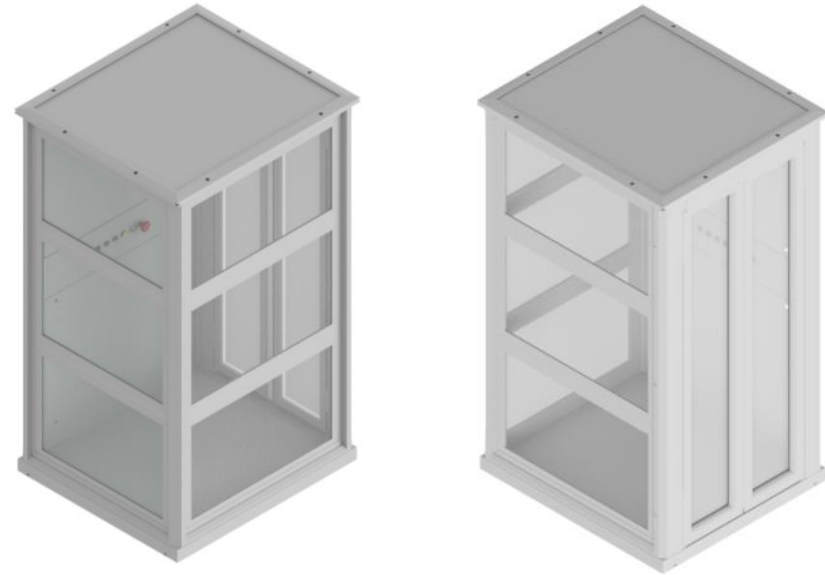

5.8 Cabin dimensions

There are 4 types of standard dimensions.

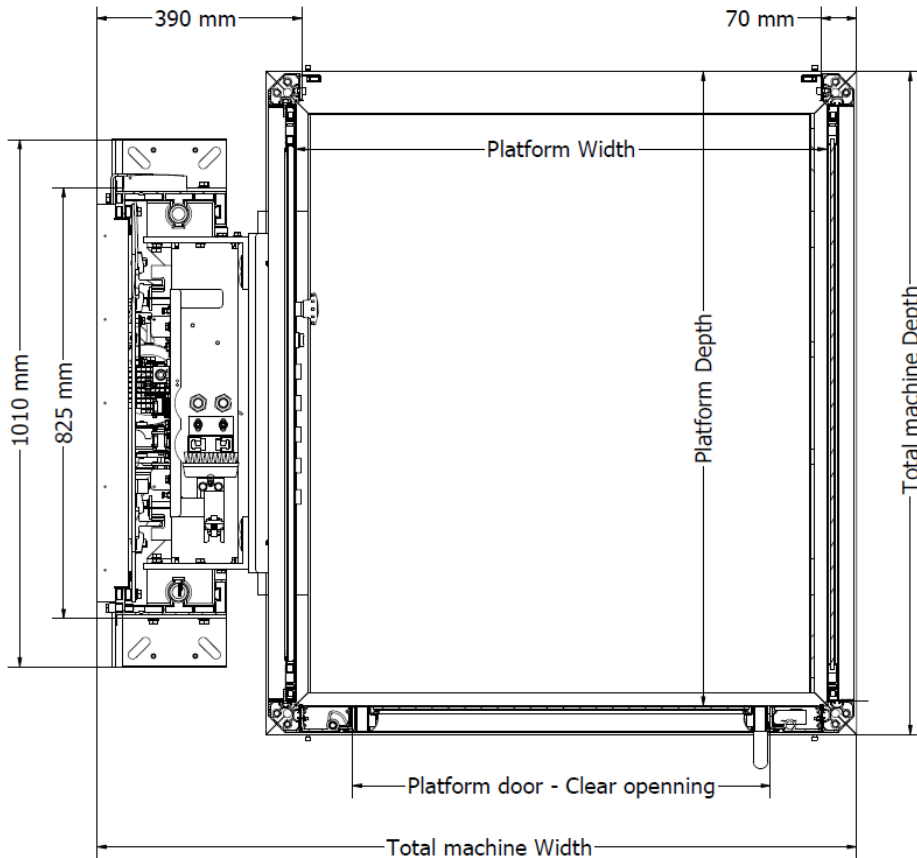

| Type | Platform dimensions | | Total Machine Dimensions | | Door opening |
|------|---------------------|---------|--------------------------|-------|--------------|
| | Width | Depth** | Width | Depth | Width |
| A | 820 | 1215 | 1246 | 1300 | 600 |
| B | 1020 | 1215 | 1446 | 1300 | 800 |
| C | 1120 | 1485 | 1546 | 1570 | 900 |
| D | 1120 | 1605 | 1546 | 1690 | 900 |

**All dimensions are given in millimeters (mm).*

***If the cabin is equipped with a double-leaf door, the platform depth is reduced by 50 mm.*

6. COLUMN

The column consists of two vertical aluminum pillars and separate sections that are placed on top of each other. The first section, which is positioned on the ground, is different from the rest both in length and in structure. The chassis moves smoothly over special plastic sliders, while the front and back sides of the column are covered with blind sheets.

6.1 Column division (parts) per total travel

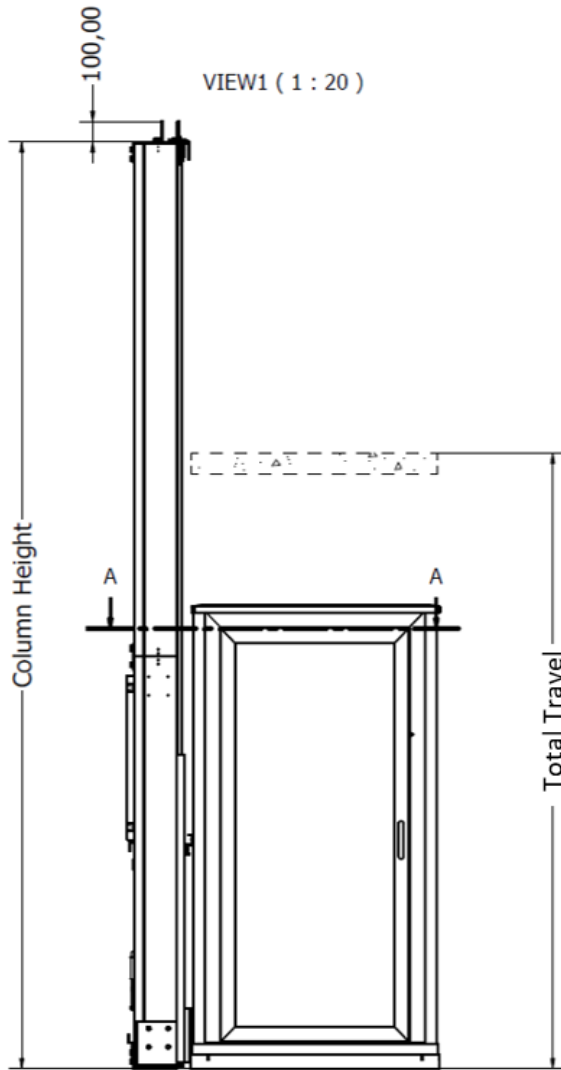

| Total Travel | Column Height | Part 1 | Part 2 | Part 3 | Part 4 | Part 5 | Part 6 |
|--------------|---------------|--------|--------|--------|--------|--------|--------|
| 420 | 2000 | 2000 | | | | | |
| 920 | 2500 | 2500 | | | | | |
| 1420 | 3000 | 2000 | 1000 | | | | |
| 1920 | 3500 | 2500 | 1000 | | | | |
| 2420 | 4000 | 2000 | 2000 | | | | |
| 2920 | 4500 | 2000 | 2500 | | | | |
| 3420 | 5000 | 2500 | 2500 | | | | |
| 3920 | 5500 | 2000 | 2500 | 1000 | | | |
| 4420 | 6000 | 2000 | 2000 | 2000 | | | |
| 4920 | 6500 | 2000 | 2500 | 2000 | | | |
| 5420 | 7000 | 2000 | 2500 | 2500 | | | |
| 5920 | 7500 | 2500 | 2500 | 2500 | | | |
| 6420 | 8000 | 2000 | 2000 | 2000 | 2000 | | |
| 6920 | 8500 | 2000 | 2500 | 2000 | 2000 | | |
| 7420 | 9000 | 2000 | 2500 | 2500 | 2000 | | |
| 7920 | 9500 | 2000 | 2500 | 2500 | 2500 | | |
| 8420 | 10000 | 2500 | 2500 | 2500 | 2500 | | |
| 8920 | 10500 | 2000 | 2500 | 2000 | 2000 | 2000 | |
| 9420 | 11000 | 2000 | 2500 | 2500 | 2000 | 2000 | |
| 9920 | 11500 | 2000 | 2500 | 2500 | 2500 | 2000 | |
| 10420 | 12000 | 2000 | 2500 | 2500 | 2500 | 2500 | |
| 10920 | 12500 | 2500 | 2500 | 2500 | 2500 | 2500 | |
| 11420 | 13000 | 2000 | 2500 | 2500 | 2000 | 2000 | 2000 |
| 11920 | 13500 | 2000 | 2500 | 2500 | 2500 | 2000 | 2000 |
| 12420 | 14000 | 2000 | 2500 | 2500 | 2500 | 2500 | 2000 |

**All dimensions are given in millimeters (mm).*

6.2 Column Support

Depending on the installation, the column can either be mounted directly on a wall or in the absence of a wall, supported by a triangular structure.

6.2.1 Standard Column Support – Wall support

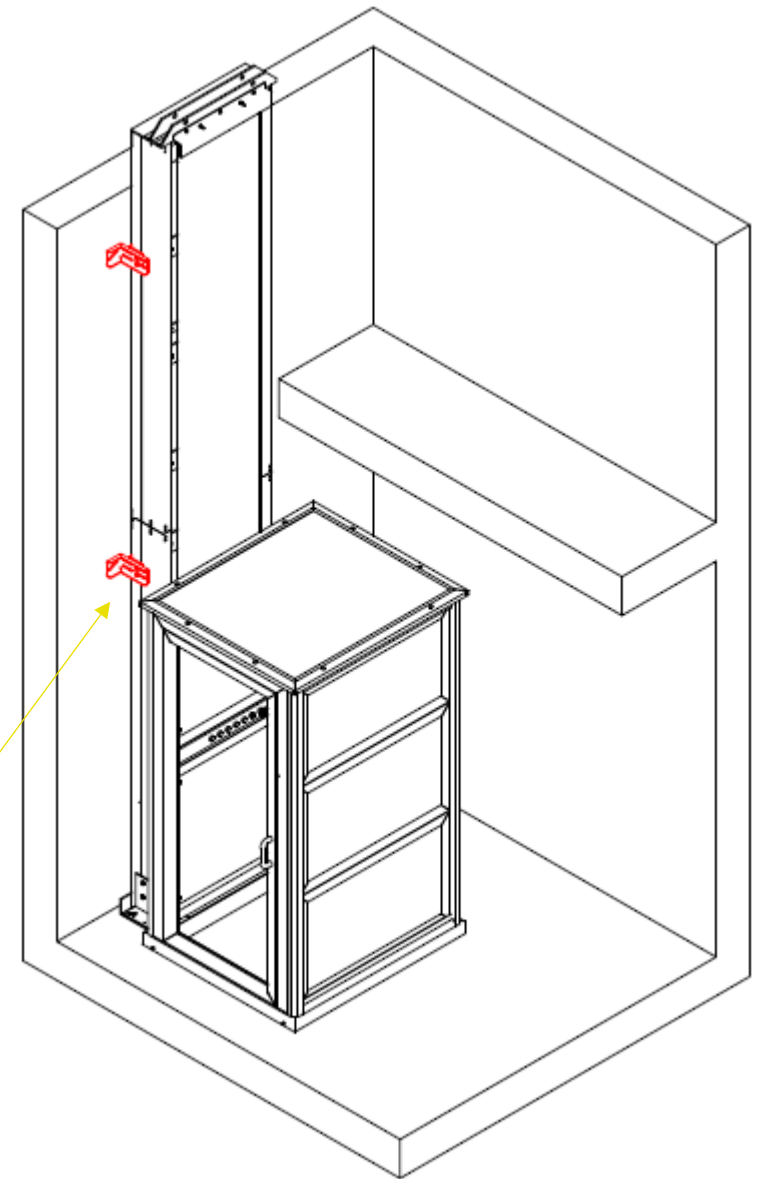
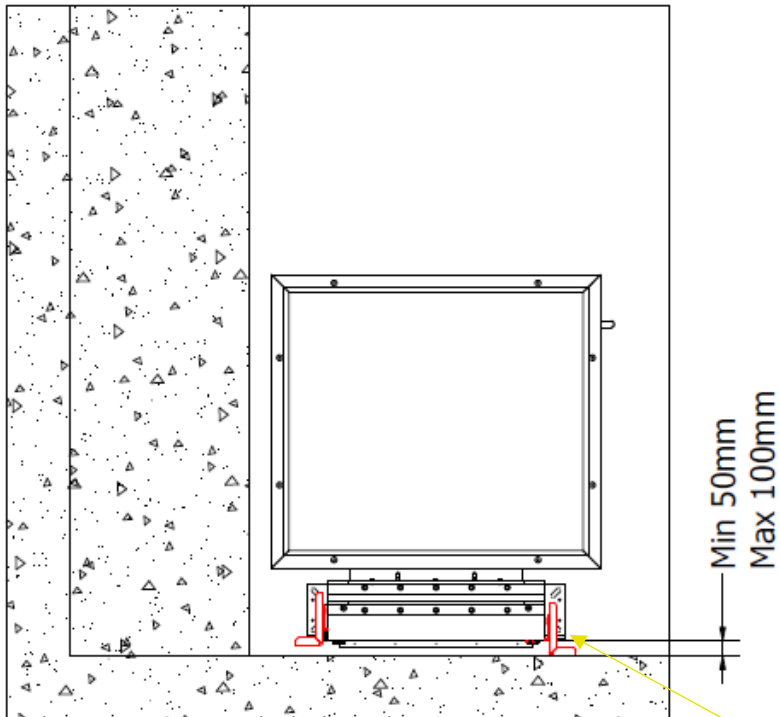

Angle support directly on the wall. It can cover differences between 50 to 100mm.

6.2.2 Optional Column Support - Triangle support

As mentioned earlier, if no wall is available behind the column, we offer the option of triangular support that can be mounted at each stop of the lift, such as on balconies.

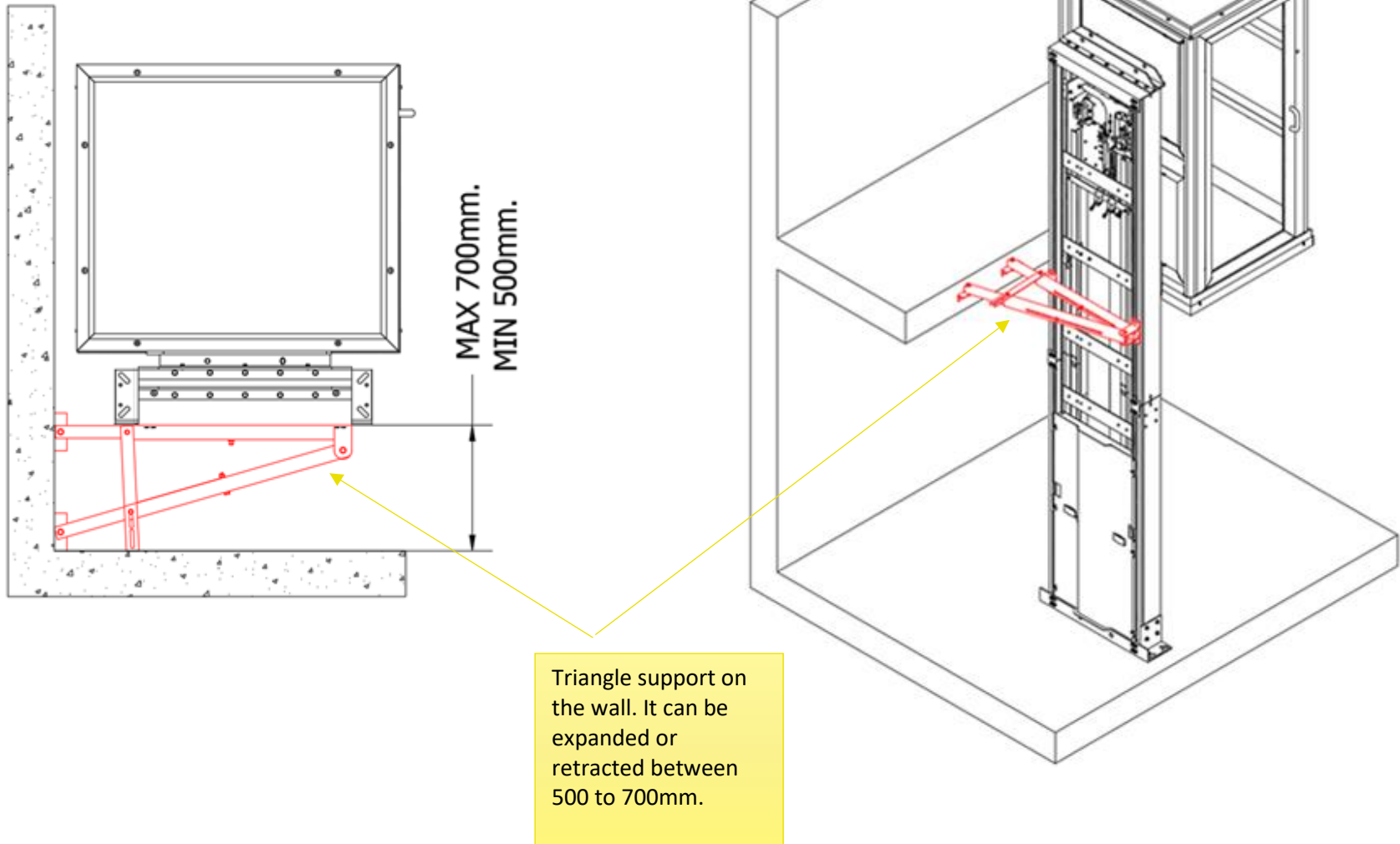

7. CONTROL PANEL & HYDRAULIC UNIT

The control panel and the hydraulic unit are installed into a cabinet

Function: Manages the operation of the hydraulic system for precise and efficient control.

Control Panel

- **Function:** Includes a variety of electrical and electronic components that work together to operate, monitor, and protect the system.
- **Components:** It mainly includes main board, power supply, switches, relays, led lights for monitoring and push buttons.

Hydraulic unit

- **Function:** Its main function is to generate, control, and supply hydraulic energy to drive the system.
- **Components:** It mainly consists of a motor, pump, tank, valves and filter that work together to generate and deliver hydraulic power.
- **Control:** Adjusts pressure, flow rate, and direction of the fluid as needed.
- **Benefits:** Improves system safety, ensures reliable and high-performance operation, and enables smooth, energy-efficient control of hydraulic processes.

The oil tank has a capacity of 30L and the max pressure is up to 80 -120 bar.



8. CABINET FOR THE CONTROL PANEL & HYDRAULIC UNIT

Space - Saving Design: Measuring at 900mm in height, 450mm in width and 550mm in depth, this cabinet fits seamlessly into tight spaces, making it ideal for installations with limited room.

Durable Construction: Built with galvanized sheet metal panels and painted in RAL 7040, the cabinet offers corrosion and water resistance (IP54), ensuring long-term durability.

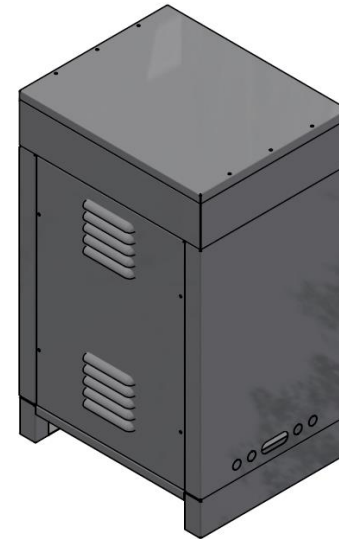
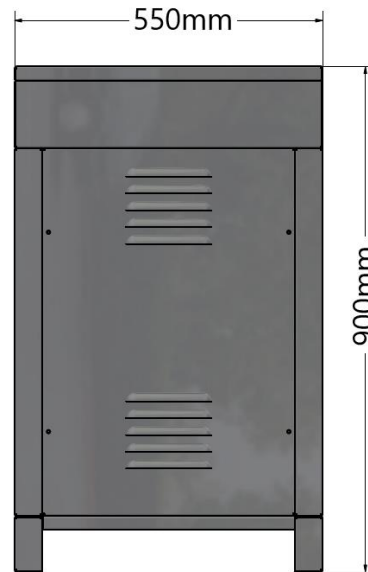
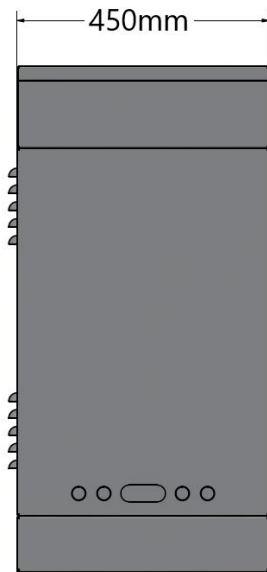

9. FORCES

9.1 Forces at the pit base

The forces have been calculated for a maximum load of 420 kg and platform external dimensions of 1600 x 1250 mm.

The applied forces are: 60.000 N

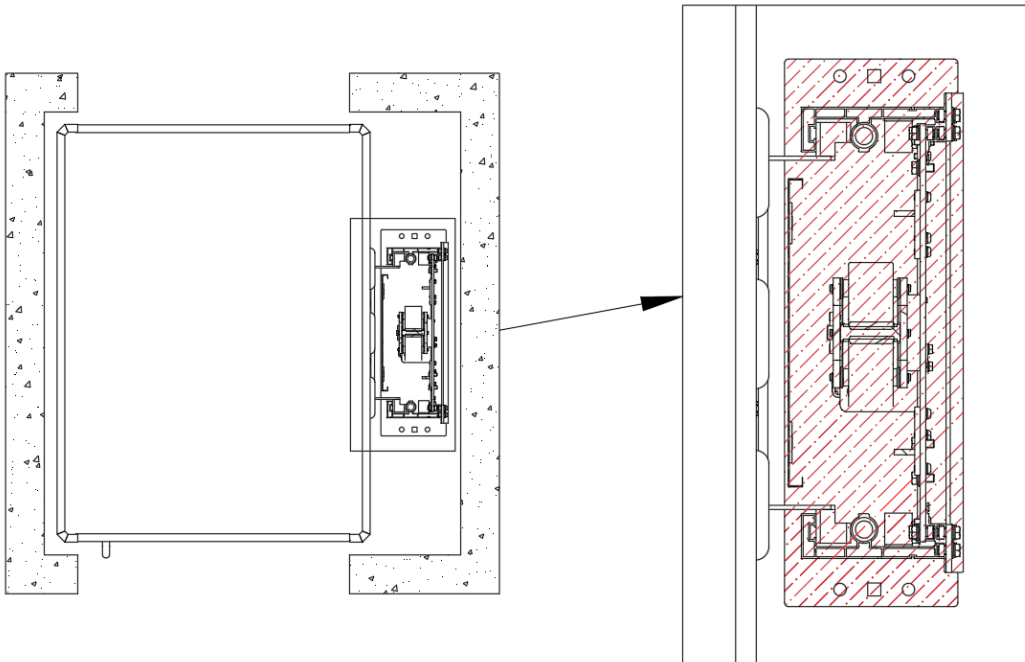

9.2 Forces on the shaft wall

The forces applied to the shaft along the x-axis are:

$$F_x = 9200 \text{ N}$$

$$F_y = 920 \text{ N}$$

The forces applied to the shaft along the y-axis are:

$$F_x = 8500 \text{ N}$$

$$F_y = 2500 \text{ N}$$

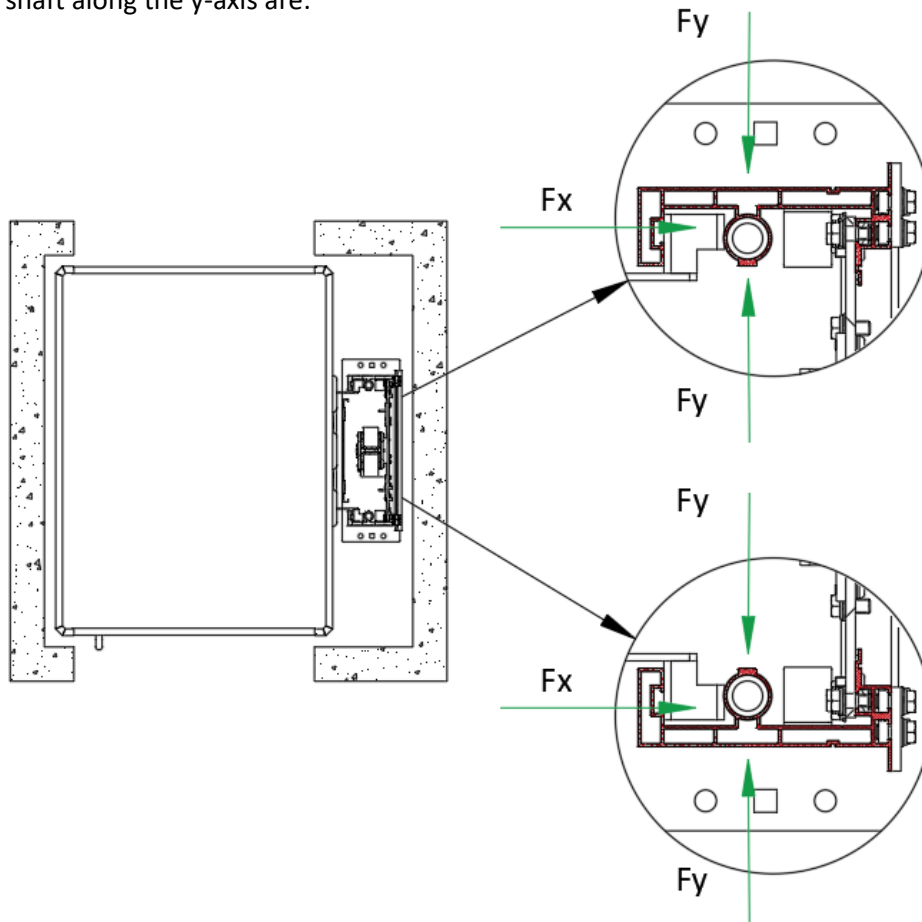

10. OPTIONAL EQUIPMENT

10.1 Level Doors

10.1.1 Description & available options

- ✓ **Single doors.**
- ✓ **Operation:** Semi-automatic operation.
- ✓ **Hinge:** Left or right.
- ✓ **Clear Height:** 1100mm or 2000mm.
- ✓ **Lining:** Triplex glass, polycarbonate sheet or blind panel.
- ✓ **LOPs** are integrated on the doors with continuous pressure call button.
- ✓ **Installation Options:** Doors can be fixed freestanding on the level floor, mounted directly onto the building wall or integrated into the barrier.

Door height 1100mm

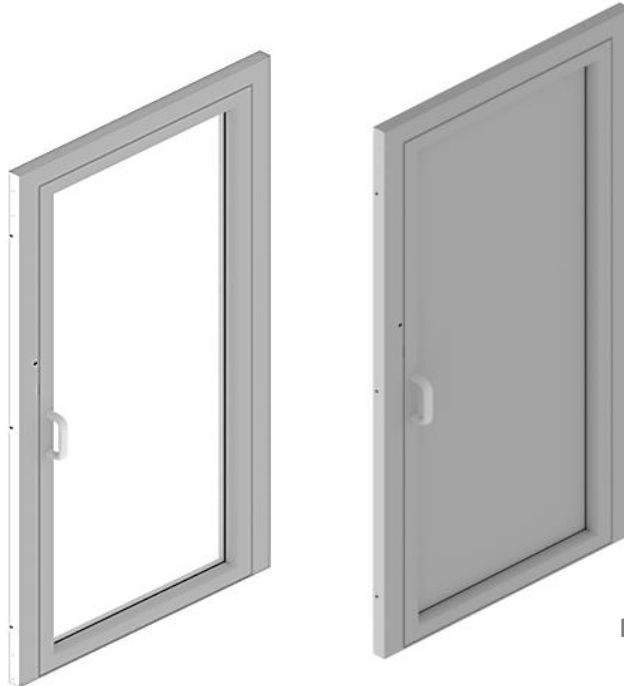

Door height 2000mm

10.1.2 Door height 1100mm

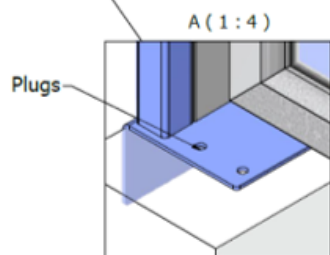
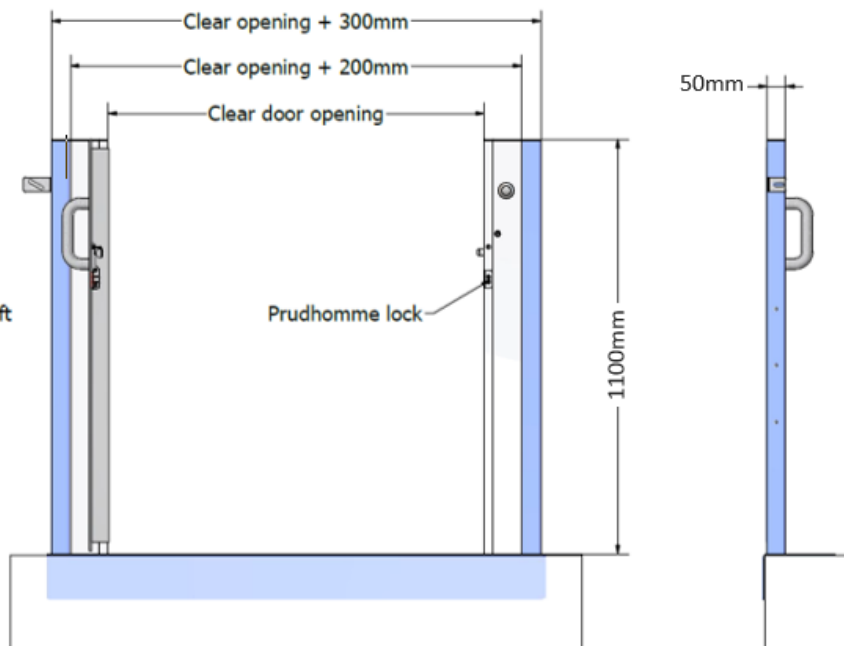
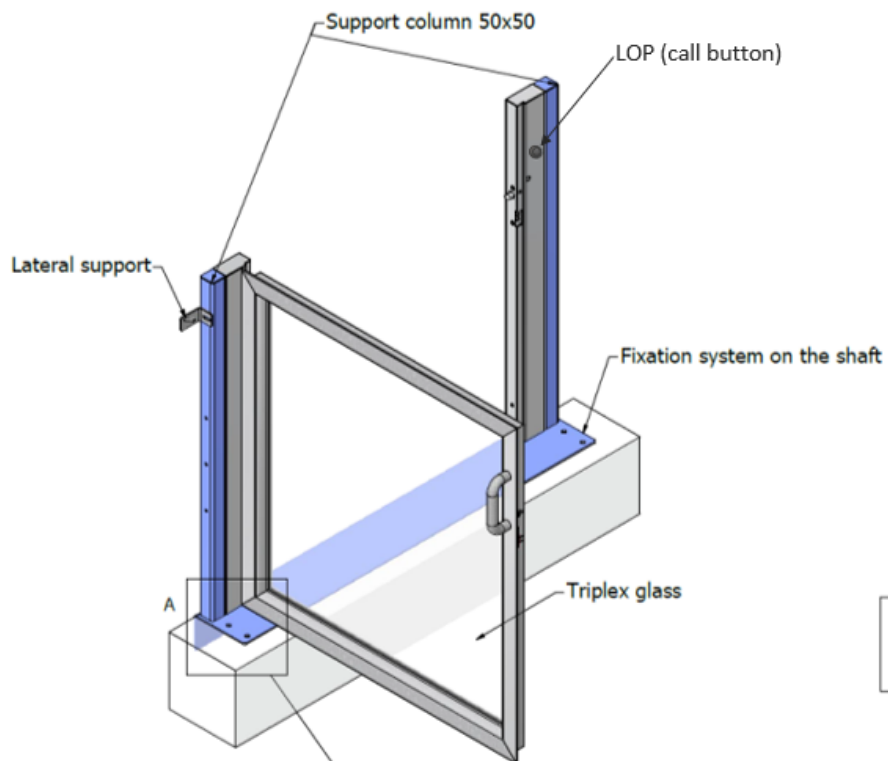

STANDARD DOOR DIMENSIONS

| Type | Clear opening | Total width | Clear height |
|------|---------------|-------------|--------------|
| A | 600mm | 900mm | 1100mm |
| B | 800mm | 1100mm | 1100mm |
| C | 900mm | 1200mm | 1100mm |
| D | 900mm | 1200mm | 1100mm |

10.1.3 Door height 2000mm

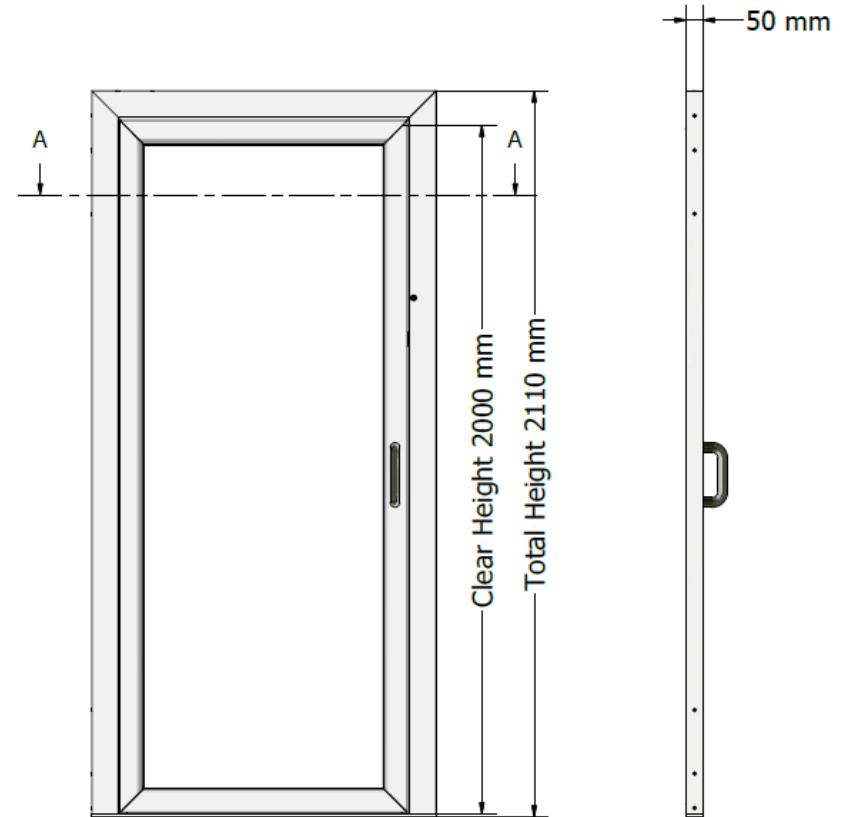
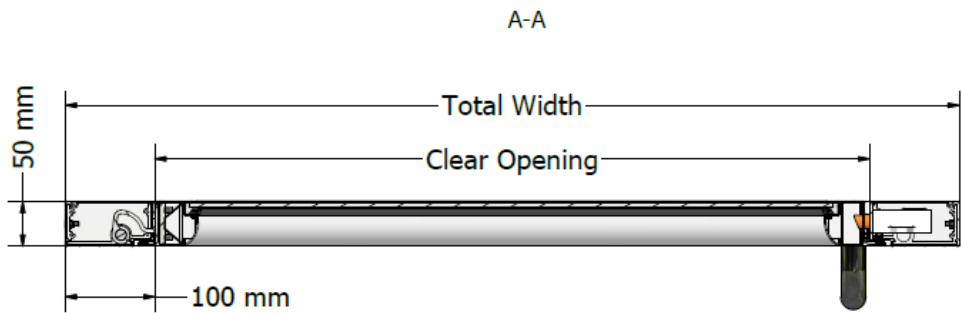

STANDARD DOOR DIMENSIONS

| Type | Clear opening | Total width | Clear height | Total height |
|------|---------------|-------------|--------------|--------------|
| A | 600mm | 800mm | 2000mm | 2110mm |
| B | 800mm | 1000mm | 2000mm | 2110mm |
| C | 900mm | 1100mm | 2000mm | 2110mm |
| D | 900mm | 1100mm | 2000mm | 2110mm |

10.2 Aluminium protective barrier & level doors

The protective barrier at the platform's exit is a key safety feature designed to prevent users from accidentally stepping off the platform while it is in motion, particularly in cases where there is no wall on the exit side, along the entire travel height. The doors are seamlessly integrated into the barrier, remaining securely closed during travel and unlocking only once the platform has reached the correct landing level, ensuring safe and controlled entry and exit.

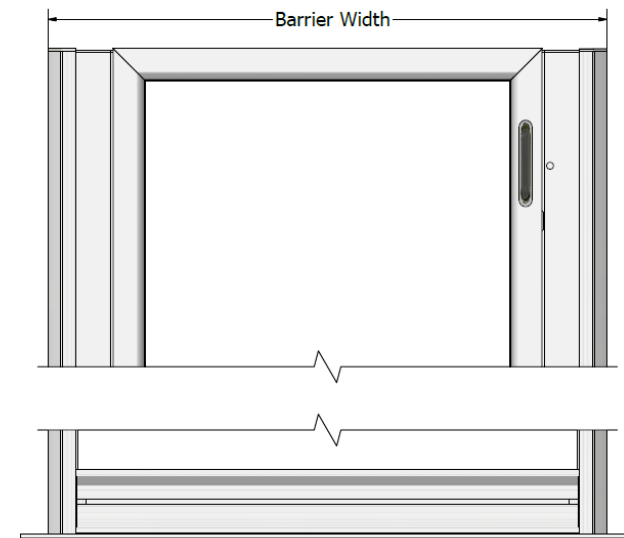
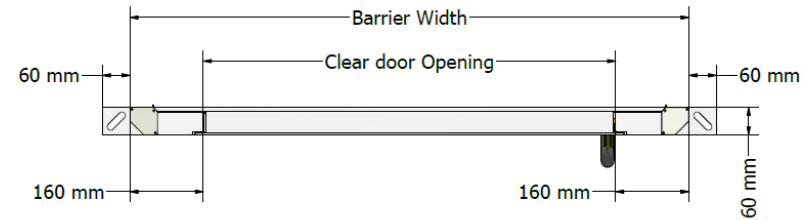

| STANDARD BARRIER & DOOR DIMENSIONS | | |
|------------------------------------|--------------------|---------------|
| Type | Door clear opening | Barrier width |
| A | 600mm | 920mm |
| B | 800mm | 1120mm |
| C | 900mm | 1220mm |
| D | 900mm | 1220mm |

10.3 Aluminium protective frames on lower landing

As optional equipment, protective shaft frames can be installed at the lower landing to safeguard the machine area wherever required. Depending on the installation layout, the system can be equipped with 2-side or 3-side protective frames at a standard height of 2100 mm, ensuring complete safety on all exposed sides of the lift.

10.3.1 Aluminium protective frames on 2 sides – “Г” shape

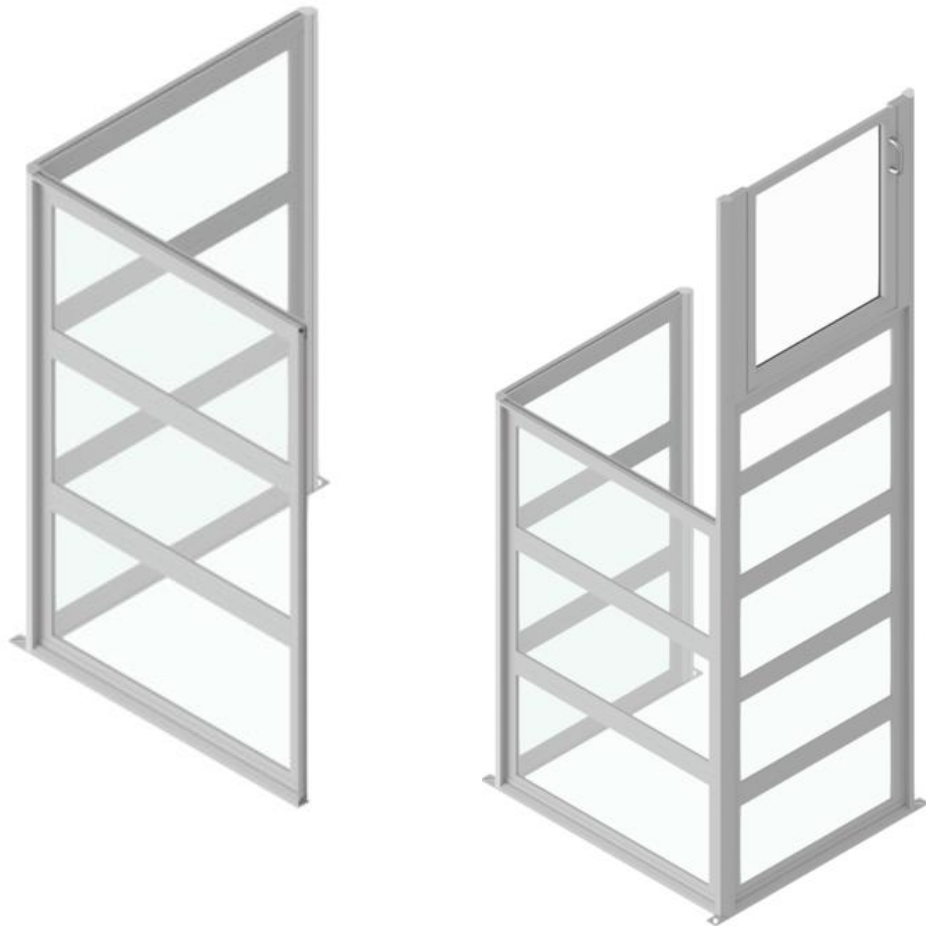

10.3.2 Aluminium protective frames on 3 sides – “П” shape

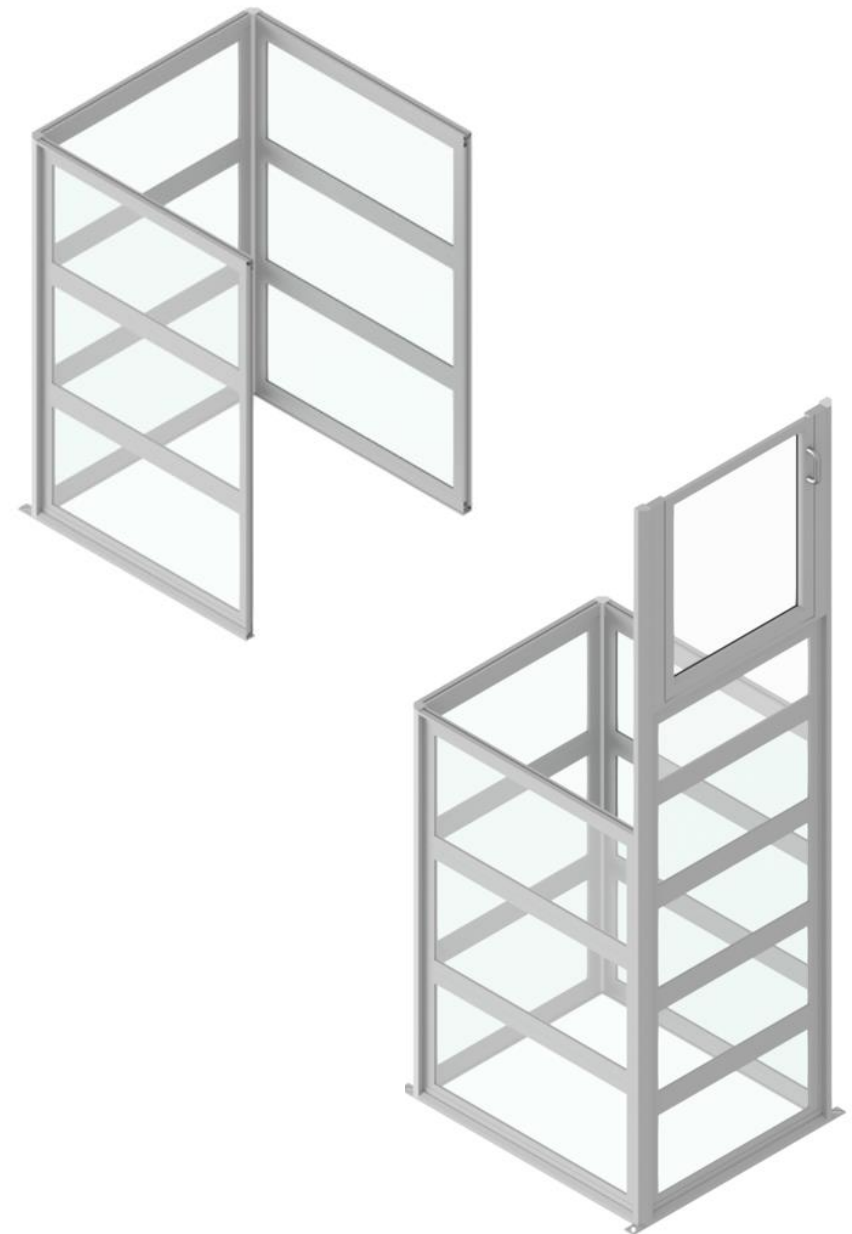

10.4 Access - Ramp

The pit required is 150mm.

In case there is not a pit a ramp can be added to close the gap.

Depending on the available space and requirements we can have the following ramp dimensions.

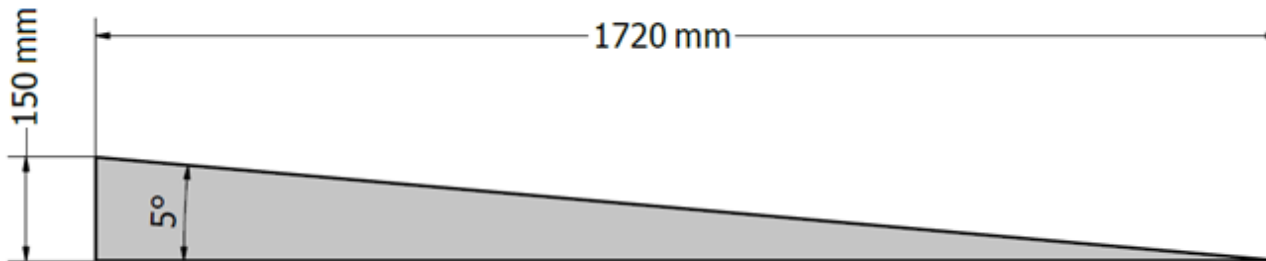
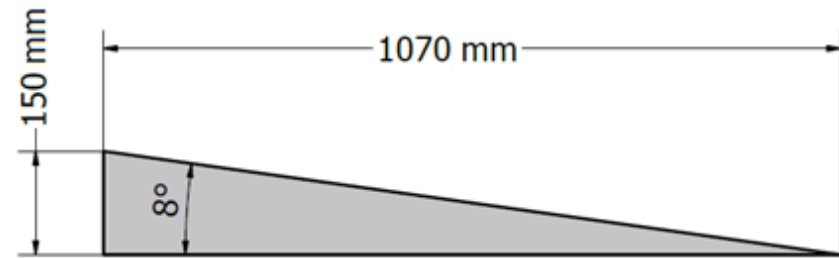
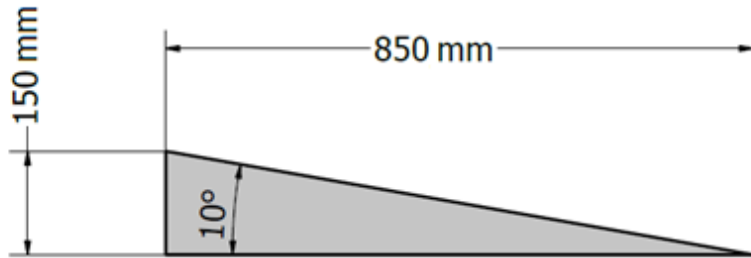

11. DETAILED DRAWINGS

11.1 Cabin type A | Entrance – Exit: Opposite sides

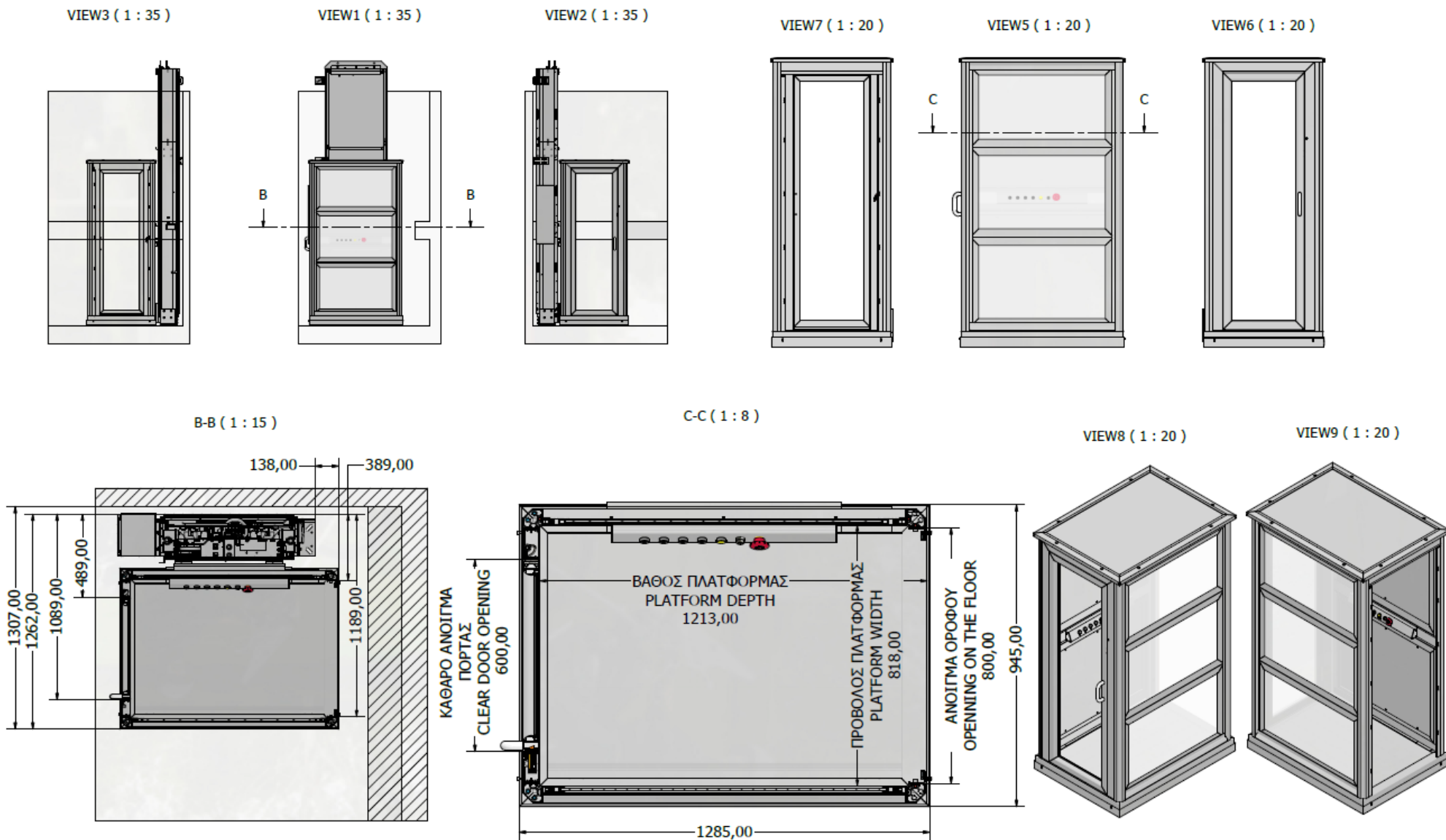

11.2 Cabin type A | Entrance – Exit: Same side

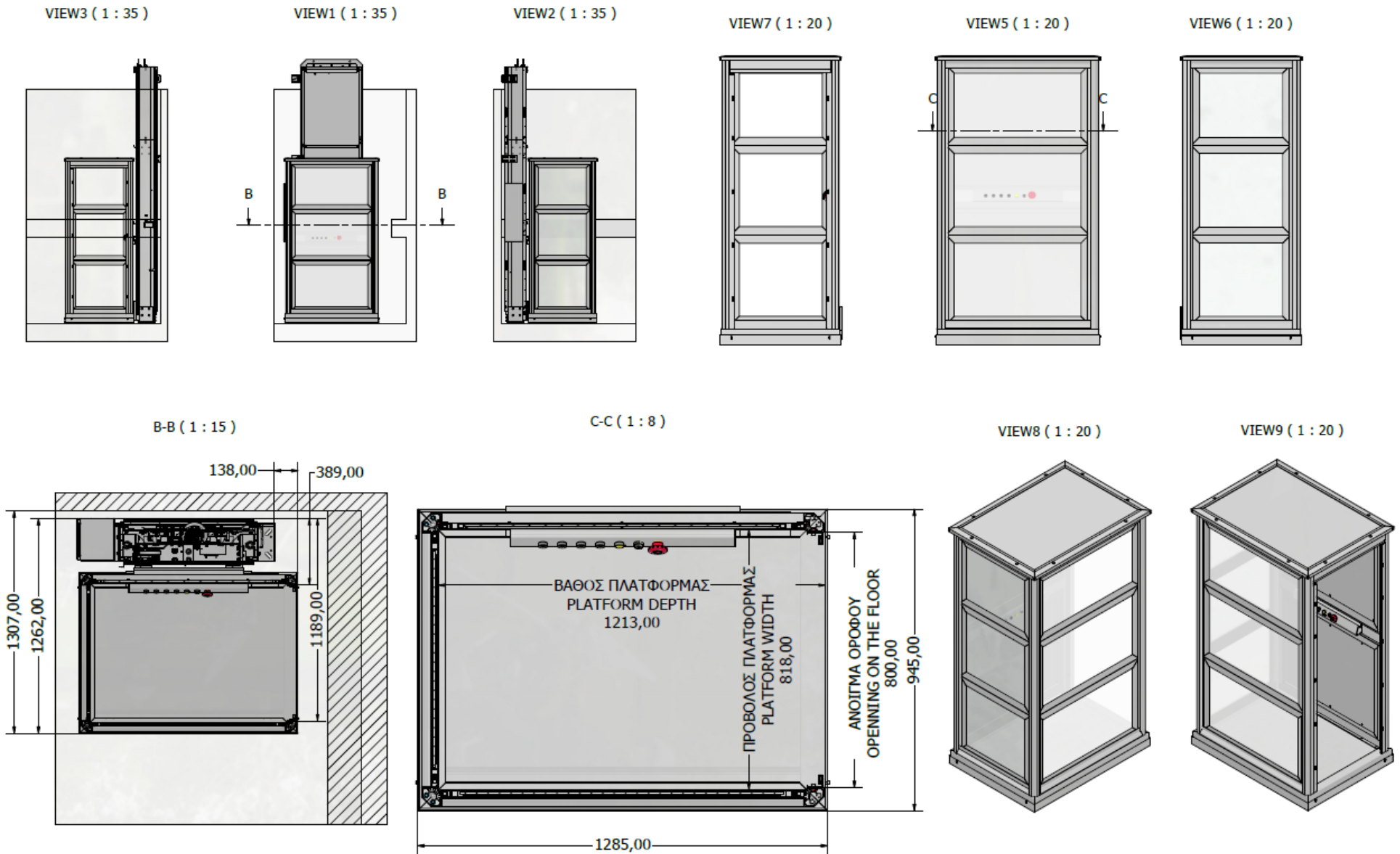

ΕΙΣΟΔΟΣ - ΕΞΟΔΟΣ: ΙΔΙΑ ΠΛΕΥΡΑ
ENTRANCE - EXIT: SAME SIDE

Type A
800 x 1200

11.3 Cabin type A | Entrance – Exit: Adjacent sides 90°

VIEW3 (1 : 35)

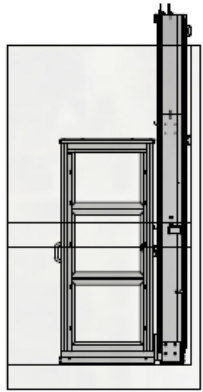

VIEW1 (1 : 35)

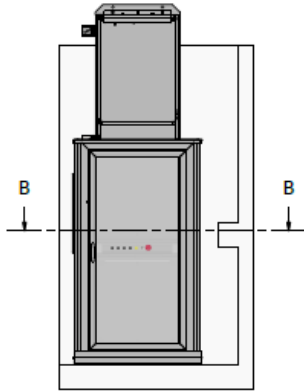

VIEW2 (1 : 35)

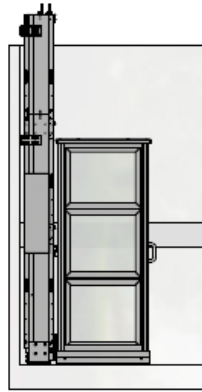

VIEW7 (1 : 20)

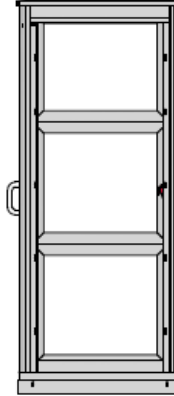

VIEW5 (1 : 20)

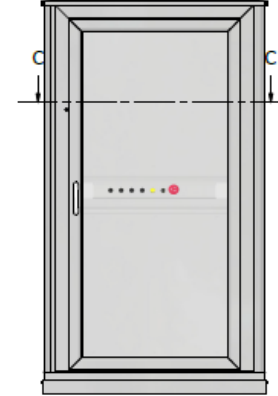

VIEW6 (1 : 20)

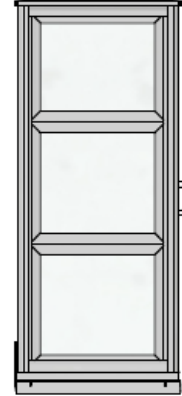

B-B (1 : 15)

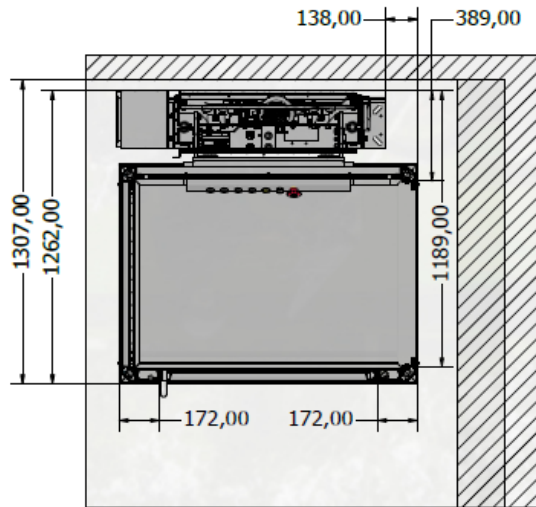

C-C (1 : 8)

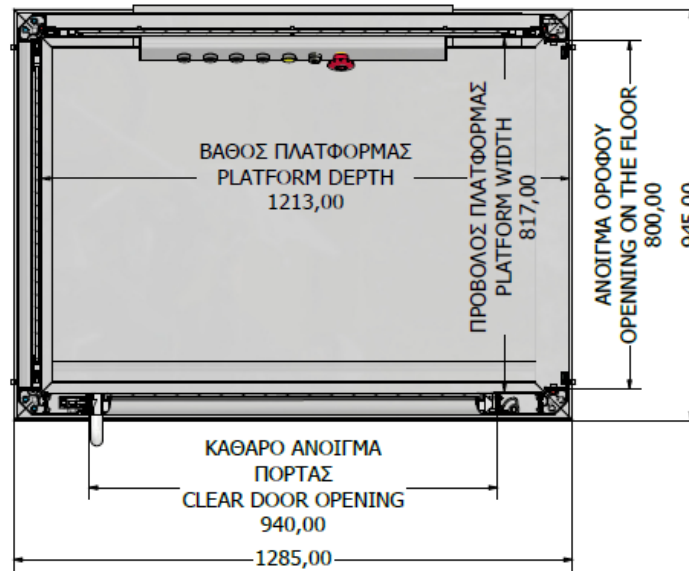

VIEW8 (1 : 20)

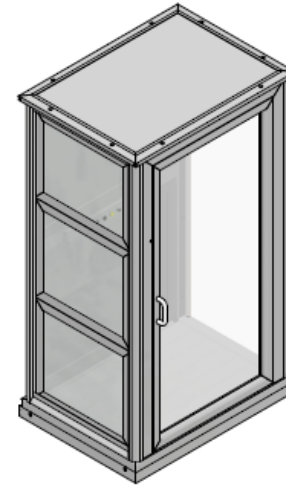

VIEW9 (1 : 20)

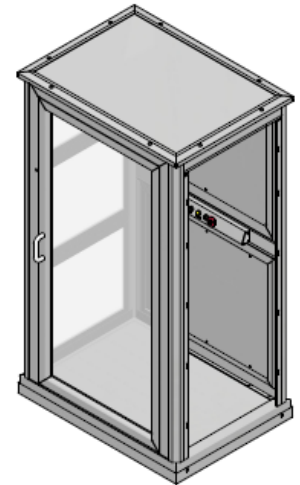

ΕΙΣΟΔΟΣ - ΕΞΟΔΟΣ: ΥΠΟ ΓΩΝΙΑ
ENTRANCE - EXIT: 90°

Type A
800 x 1200

11.4 Cabin type A | Entrance – Exit: Adjacent sides 90°

VIEW3 (1 : 35)

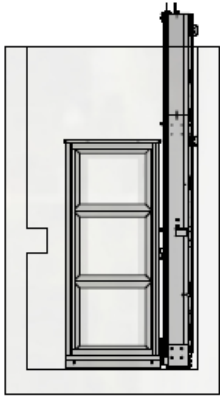

VIEW1 (1 : 35)

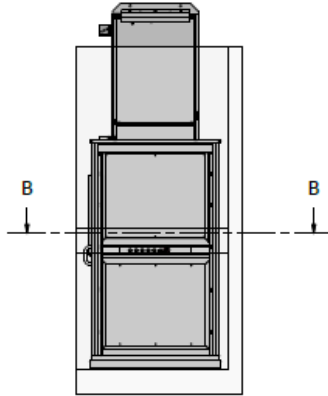

VIEW2 (1 : 35)

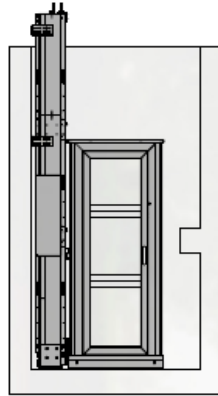

VIEW7 (1 : 20)

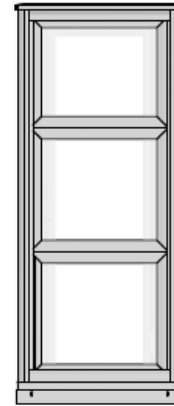

VIEW5 (1 : 20)

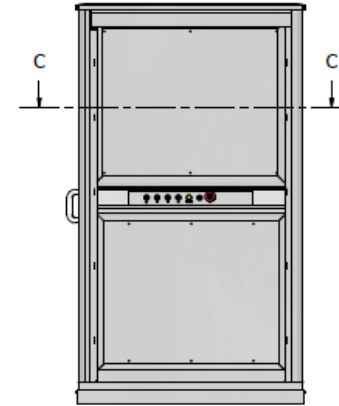

VIEW6 (1 : 20)

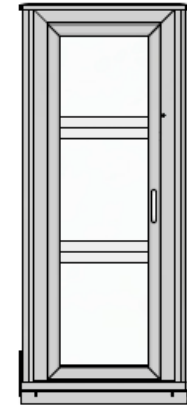

B-B (1 : 15)

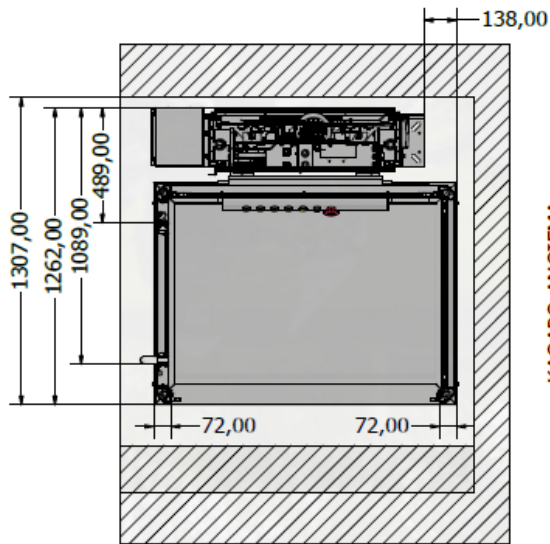

C-C (1 : 8)

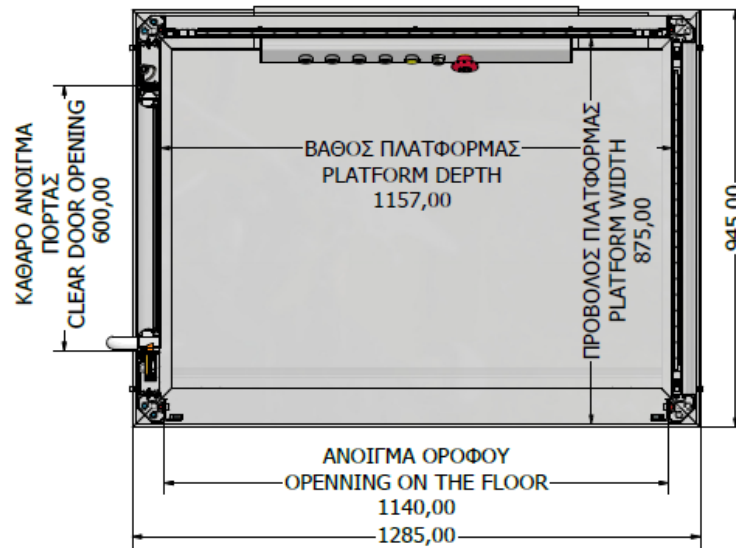

VIEW8 (1 : 20)

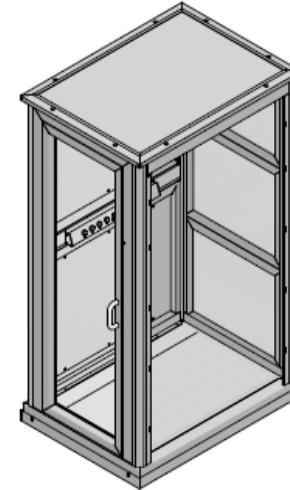

VIEW9 (1 : 20)

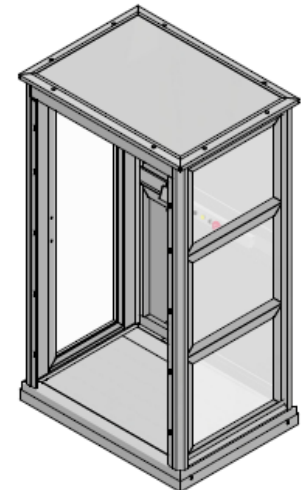

ΕΙΣΟΔΟΣ - ΕΞΟΔΟΣ: ΥΠΟ ΓΩΝΙΑ
ENTRANCE - EXIT: 90°

Type A
800 x 1200

11.5 Cabin type B | Entrance – Exit: Opposite sides

VIEW3 (1 : 35)

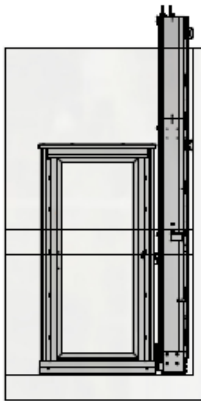

VIEW1 (1 : 35)

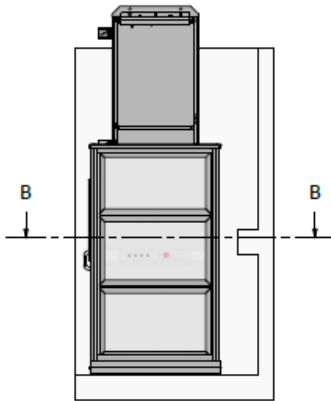

VIEW2 (1 : 35)

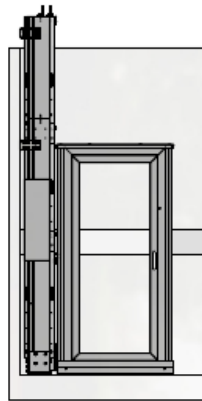

VIEW7 (1 : 20)

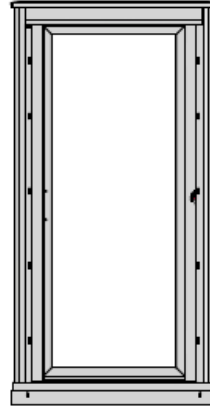

VIEW5 (1 : 20)

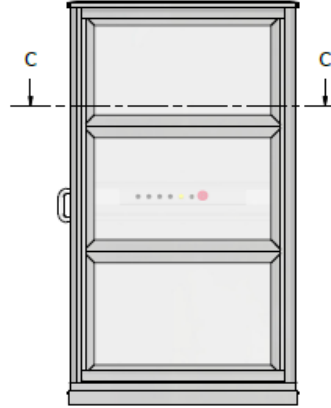

VIEW6 (1 : 20)

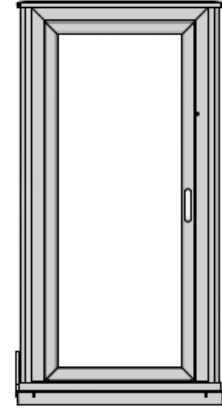

B-B (1 : 15)

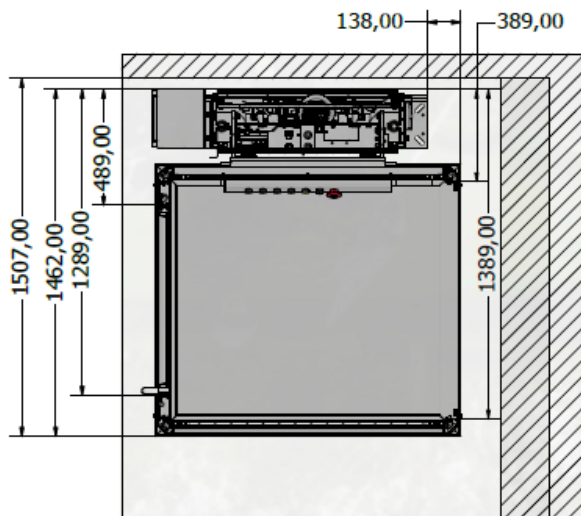

C-C (1 : 10)

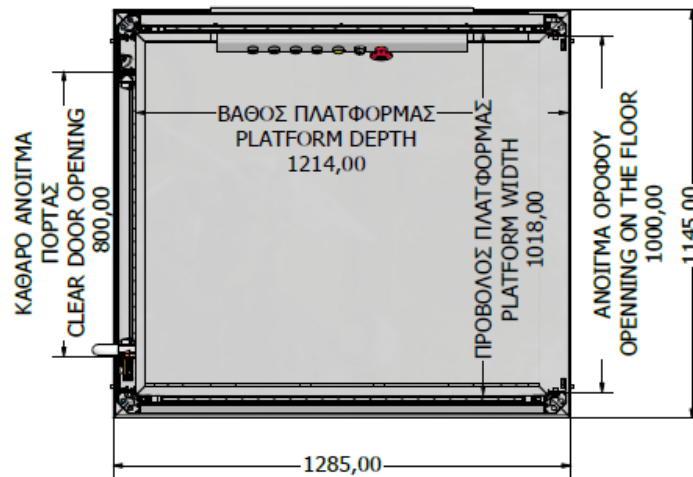

VIEW8 (1 : 20)

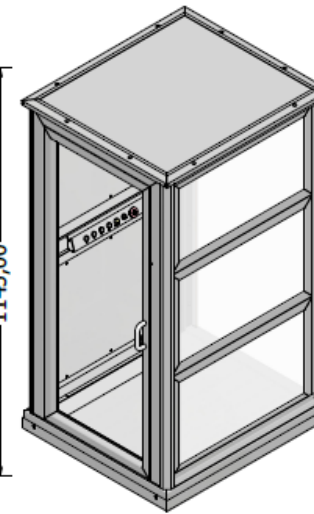

VIEW9 (1 : 20)

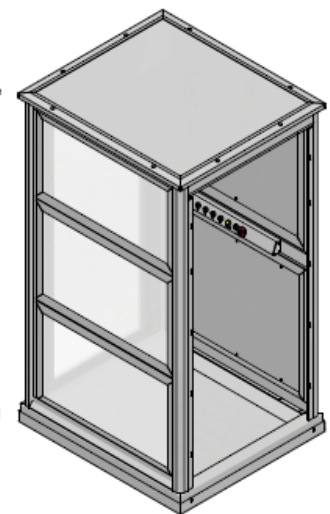

ΕΙΣΟΔΟΣ - ΕΞΟΔΟΣ: ΑΠΕΝΑΝΤΙ
ENTRANCE - EXIT: OPPOSITE

Type B
1000 x 1200

11.6 Cabin type B | Entrance – Exit: Same side

VIEW3 (1 : 35)

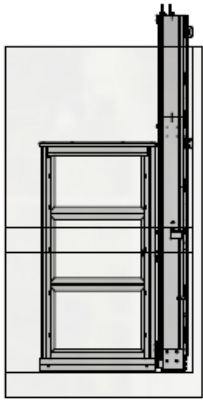

VIEW1 (1 : 35)

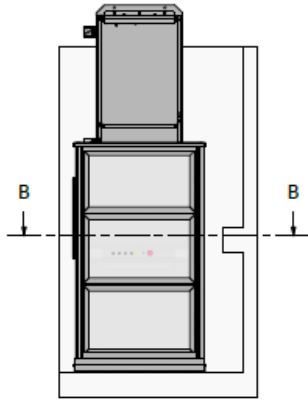

VIEW2 (1 : 35)

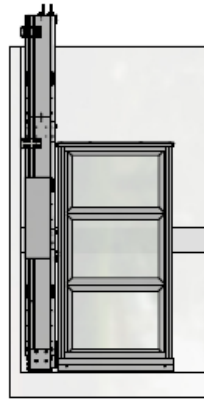

VIEW7 (1 : 20)

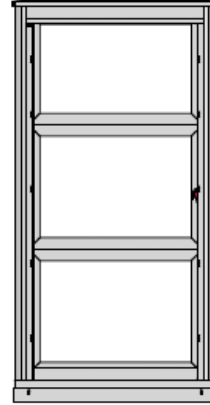

VIEW5 (1 : 20)

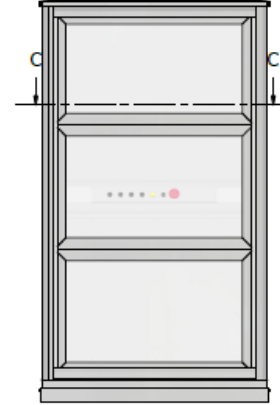

VIEW6 (1 : 20)

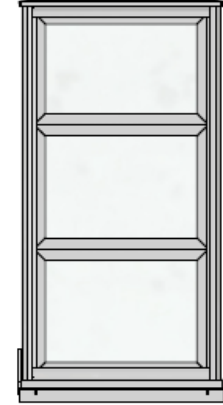

B-B (1 : 15)

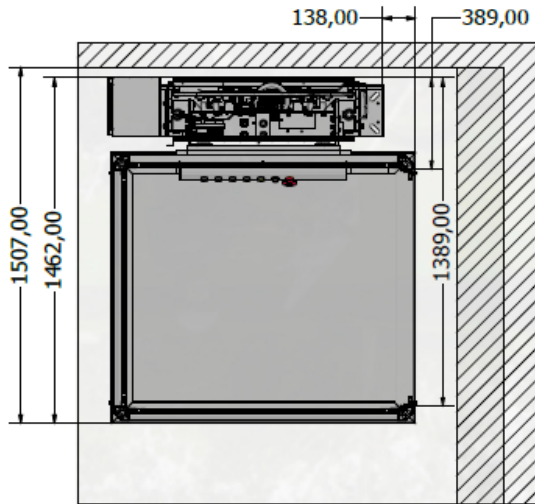

C-C (1 : 10)

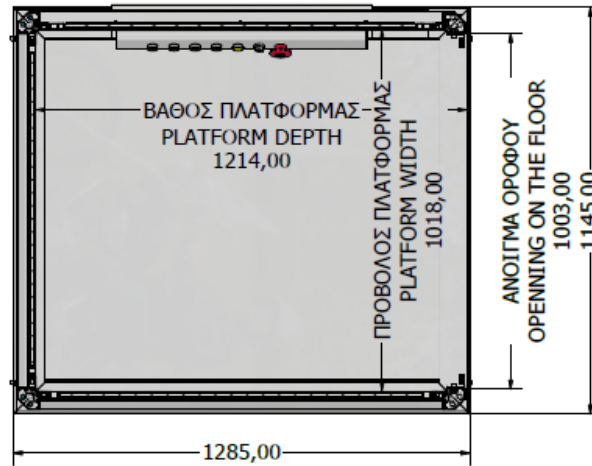

VIEW8 (1 : 20)

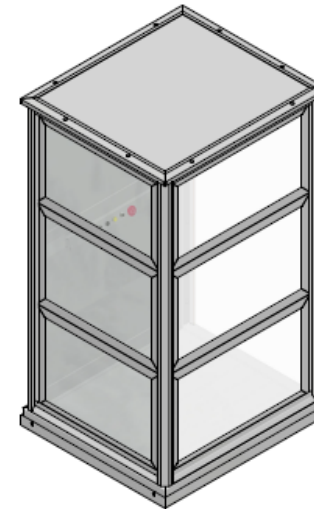

VIEW9 (1 : 20)

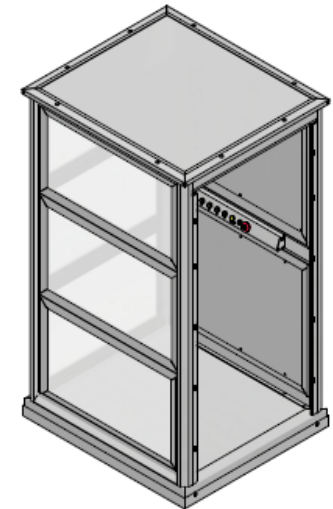

ΕΙΣΟΔΟΣ - ΕΞΟΔΟΣ: ΙΔΙΑ ΠΛΕΥΡΑ Type B
ENTRANCE - EXIT: SAME SIDE 1000 x 1200

11.7 Cabin type B | Entrance – Exit: Adjacent sides 90°

VIEW3 (1 : 35)

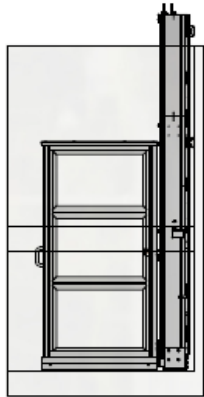

VIEW1 (1 : 35)

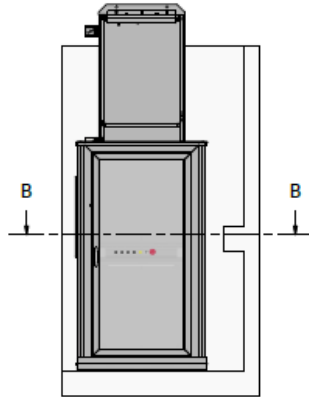

VIEW2 (1 : 35)

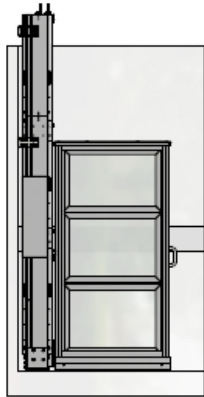

VIEW7 (1 : 20)

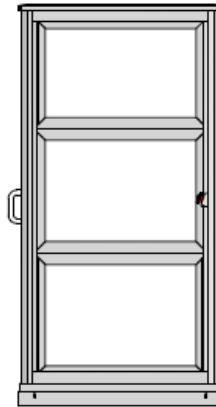

VIEW5 (1 : 20)

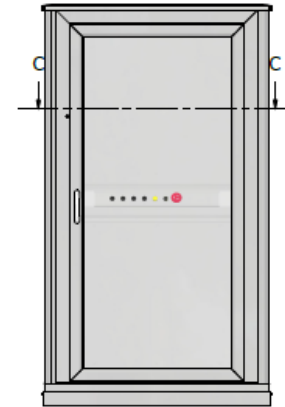

VIEW6 (1 : 20)

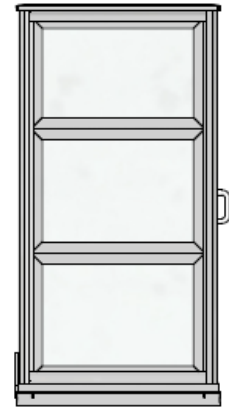

B-B (1 : 15)

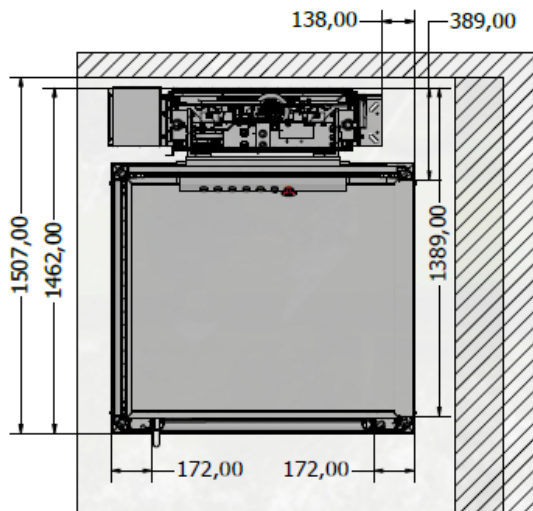

C-C (1 : 10)

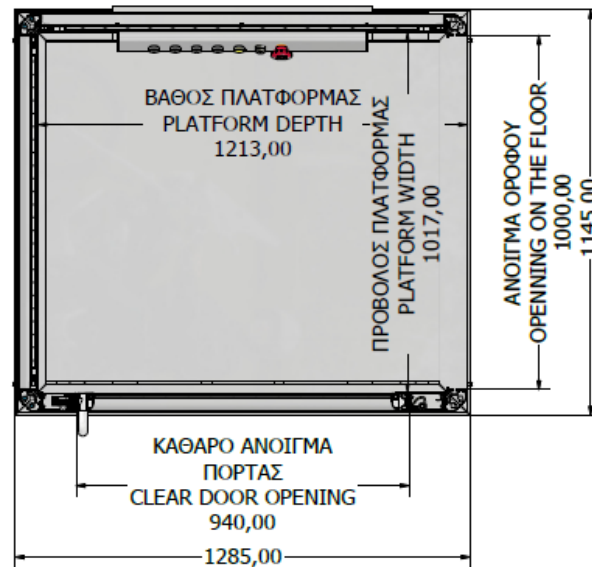

VIEW8 (1 : 20)

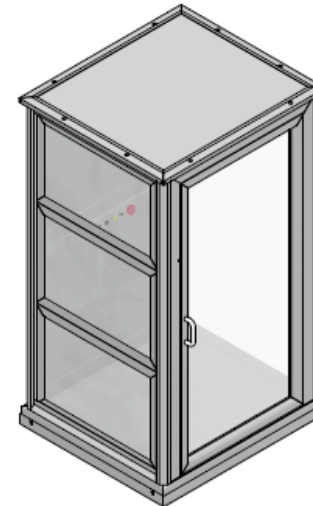

VIEW9 (1 : 20)

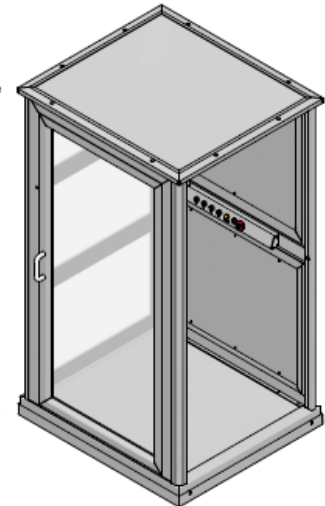

ΕΙΣΟΔΟΣ - ΕΞΟΔΟΣ: ΥΠΟ ΓΩΝΙΑ
ENTRANCE - EXIT: 90°

Type B
1000 x 1200

11.8 Cabin type B | Entrance – Exit: Adjacent sides 90°

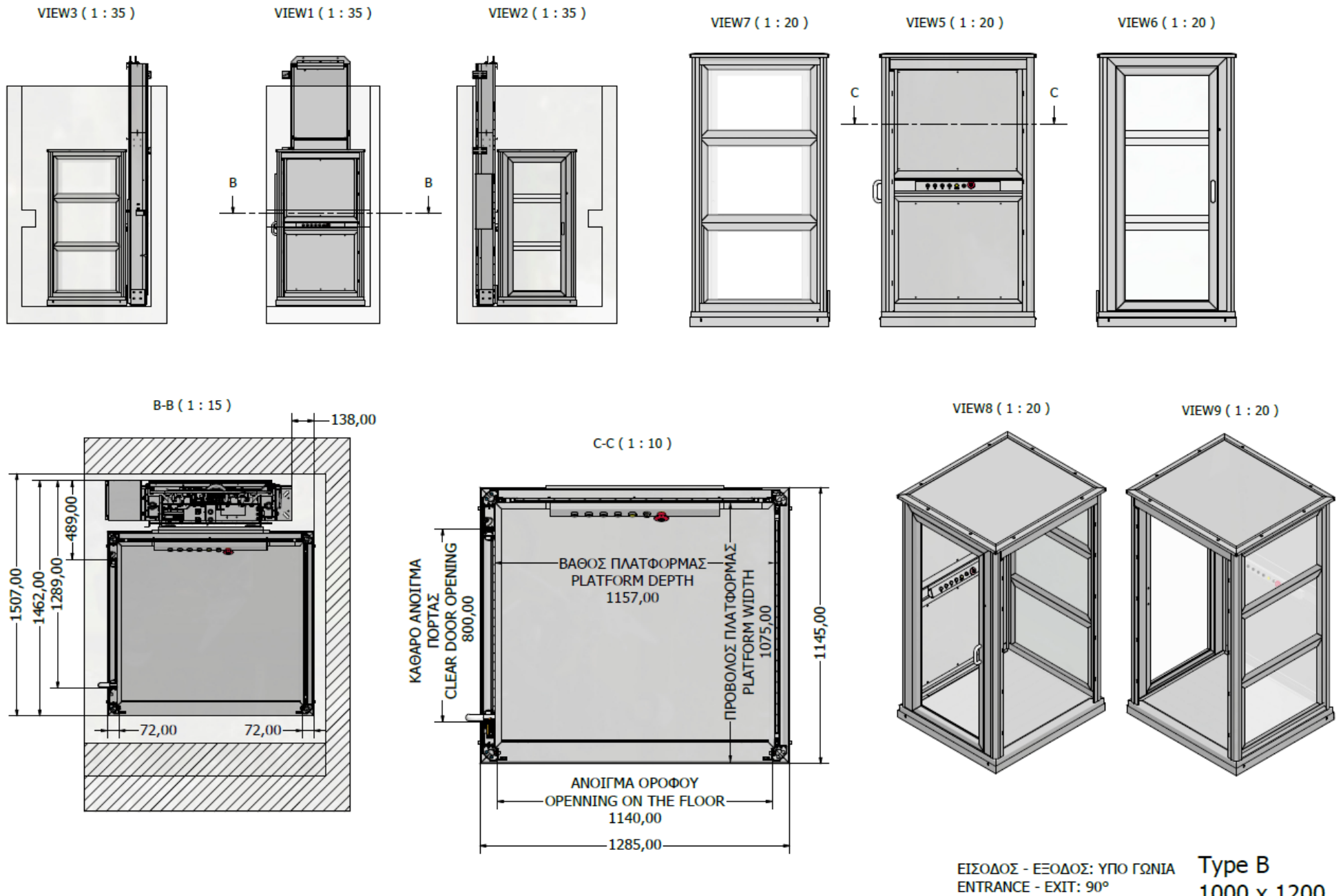

11.9 Cabin type C | Entrance – Exit: Opposite sides

VIEW3 (1 : 35)

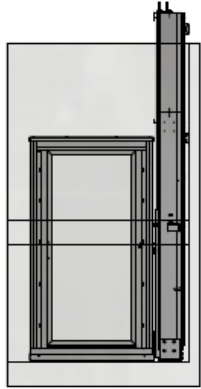

VIEW1 (1 : 35)

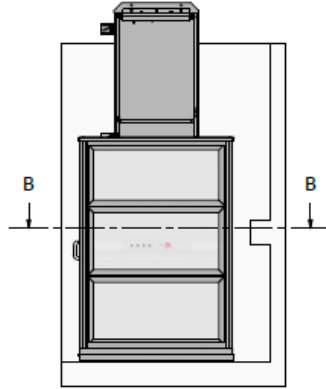

VIEW2 (1 : 35)

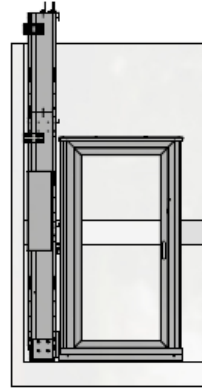

VIEW7 (1 : 20)

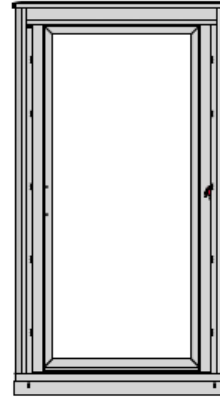

VIEW5 (1 : 20)

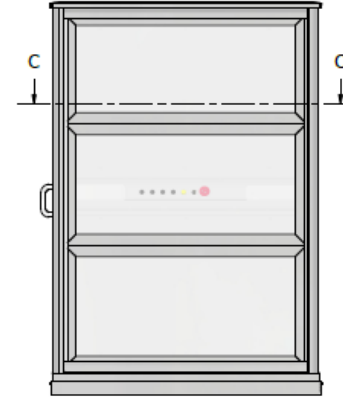

VIEW6 (1 : 20)

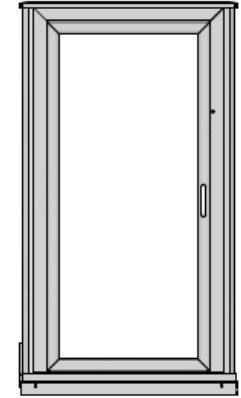

B-B (1 : 15)

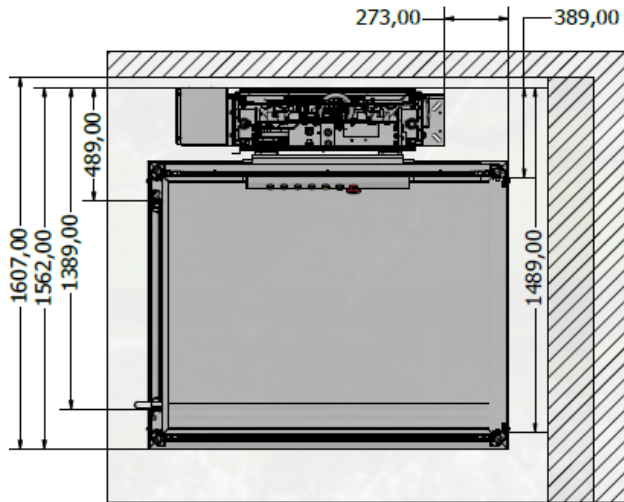

C-C (1 : 11)

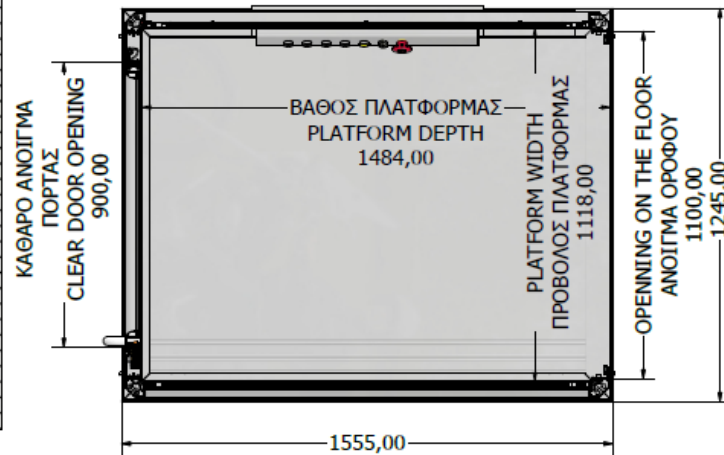

VIEW8 (1 : 23)

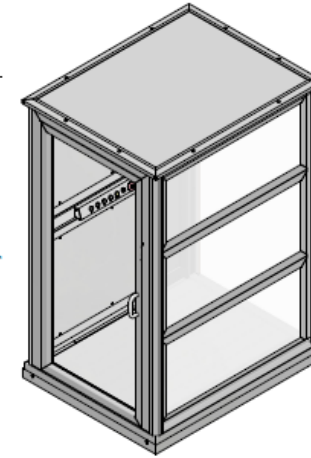

VIEW9 (1 : 23)

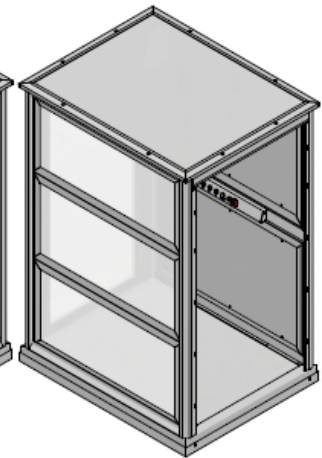

ΕΙΣΟΔΟΣ - ΕΞΟΔΟΣ: ΑΠΕΝΑΝΤΙ
 ENTRANCE - EXIT: OPPOSITE

Type C
 1100 x 1400

11.10 Cabin type C | Entrance – Exit: Same side

VIEW3 (1 : 35)

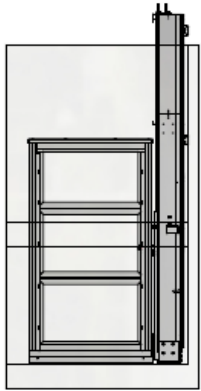

VIEW1 (1 : 35)

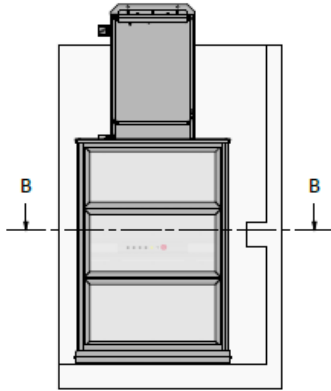

VIEW2 (1 : 35)

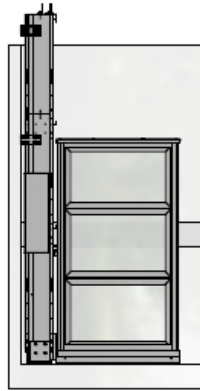

VIEW7 (1 : 20)

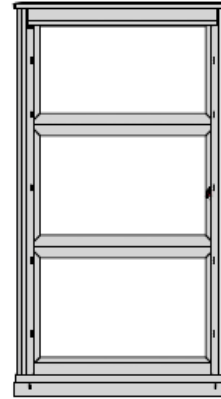

VIEW5 (1 : 20)

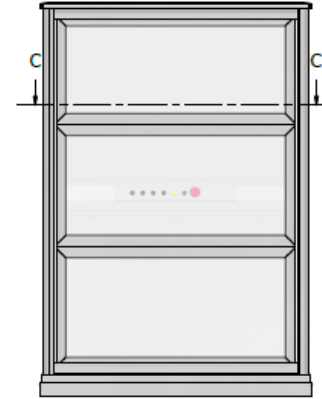

VIEW6 (1 : 20)

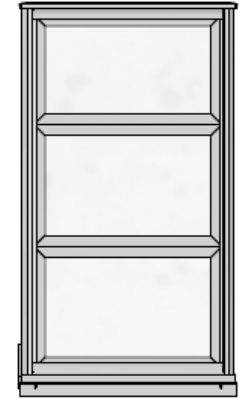

B-B (1 : 15)

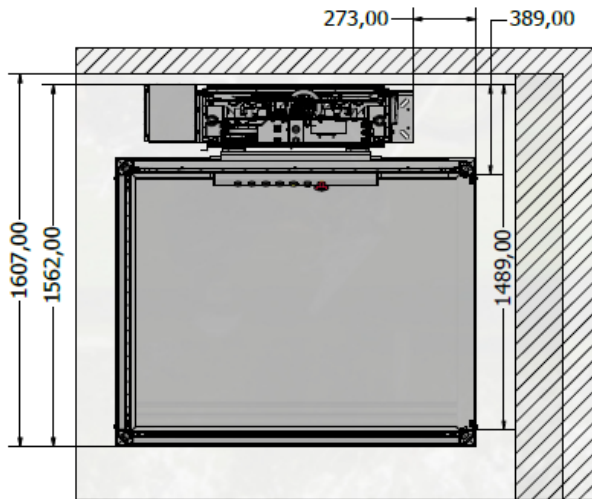

C-C (1 : 11)

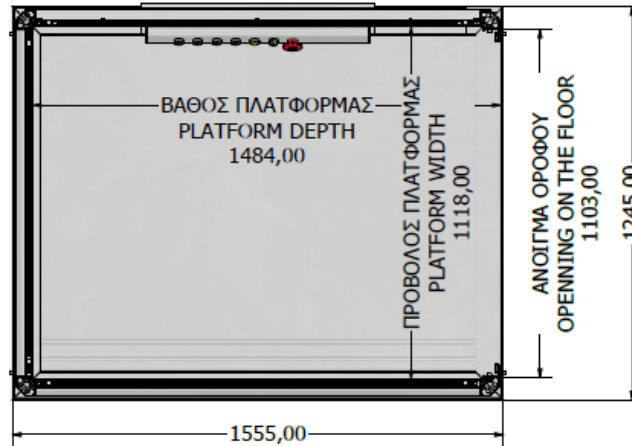

VIEW8 (1 : 23)

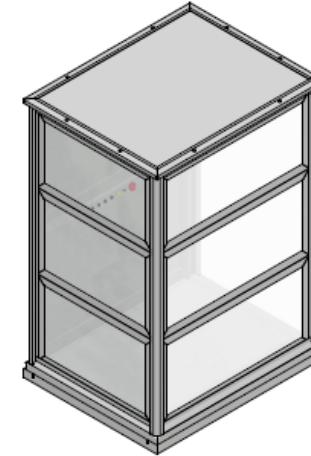

VIEW9 (1 : 23)

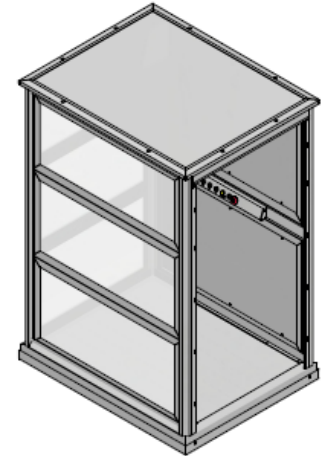

ΕΙΣΟΔΟΣ - ΕΞΟΔΟΣ: ΙΔΙΑ ΠΛΕΥΡΑ Type C
ENTRANCE - EXIT: SAME SIDE 1100 x 1400

11.11 Cabin type C | Entrance – Exit: Adjacent sides 90°

VIEW3 (1 : 35)

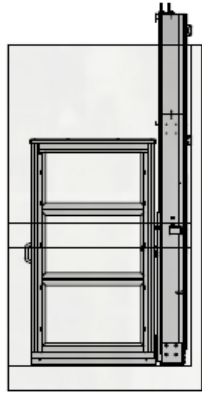

VIEW1 (1 : 35)

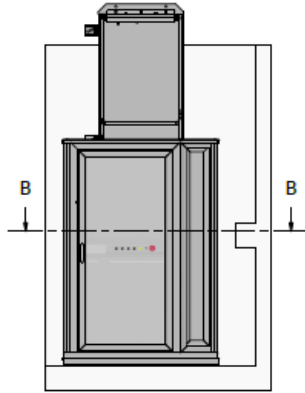

VIEW2 (1 : 35)

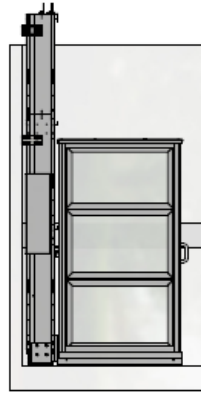

VIEW7 (1 : 20)

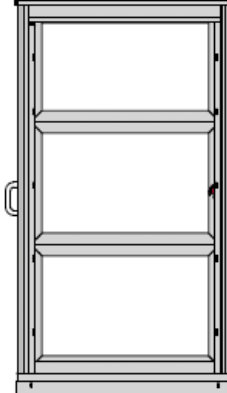

VIEW5 (1 : 20)

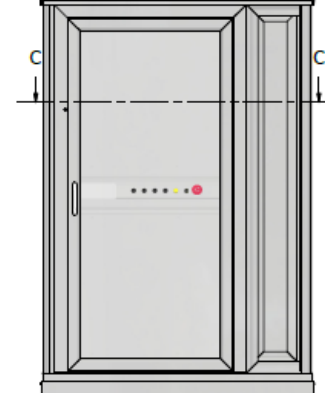

VIEW6 (1 : 20)

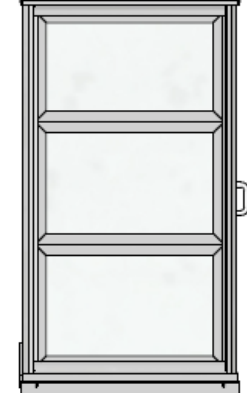

B-B (1 : 15)

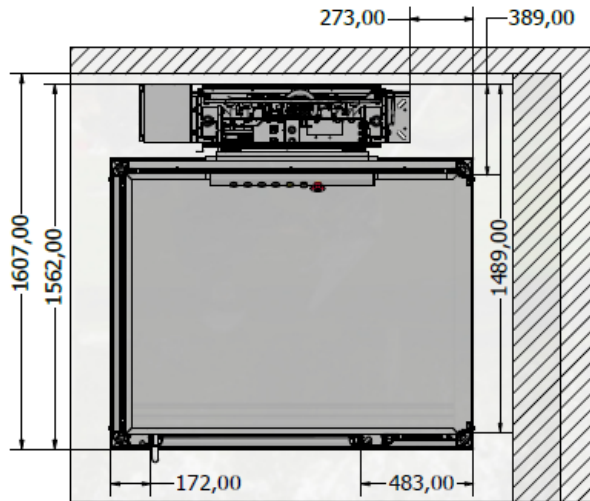

C-C (1 : 11)

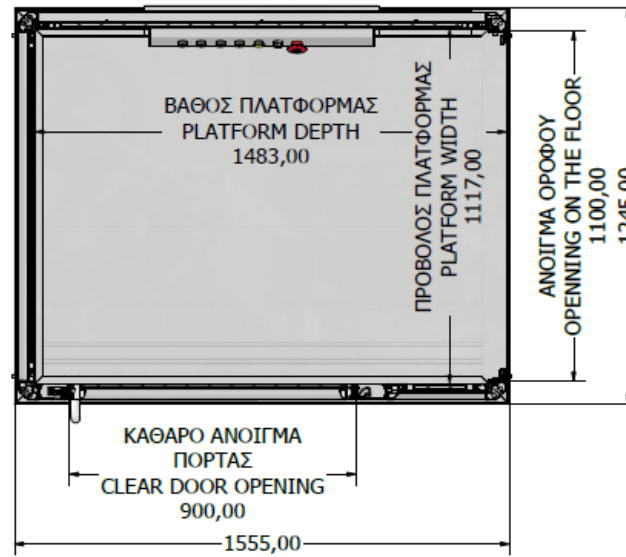

VIEW8 (1 : 23)

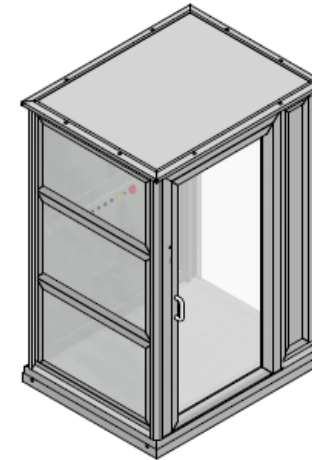

VIEW9 (1 : 23)

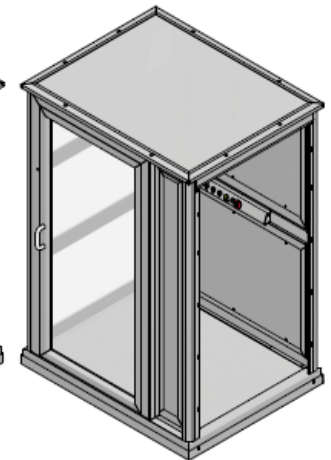

ΕΙΣΟΔΟΣ - ΕΞΟΔΟΣ: ΥΠΟ ΓΩΝΙΑ
 ENTRANCE - EXIT: 90°

Type C
 1100 x 1400

11.12 Cabin type C | Entrance – Exit: Adjacent sides 90°

VIEW3 (1 : 35)

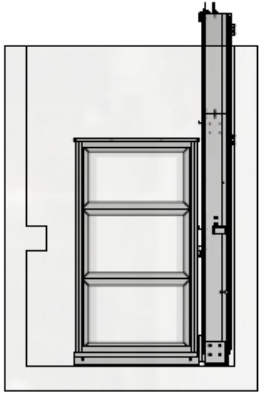

VIEW1 (1 : 35)

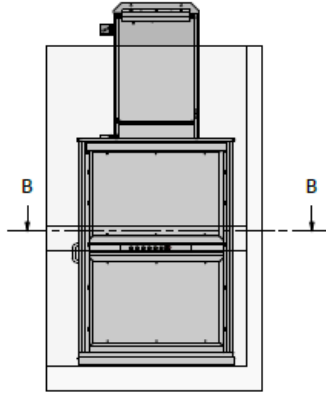

VIEW2 (1 : 35)

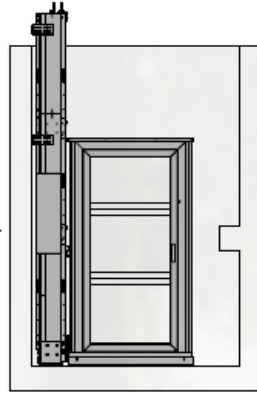

VIEW7 (1 : 20)

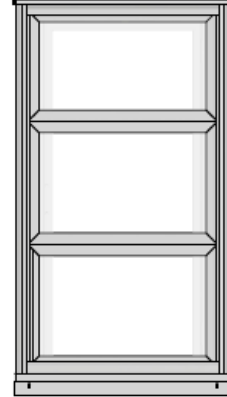

VIEW5 (1 : 20)

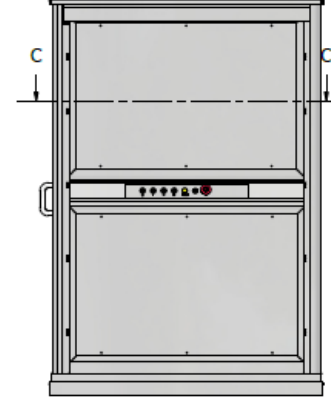

VIEW6 (1 : 20)

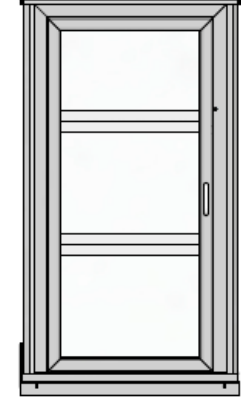

B-B (1 : 15)

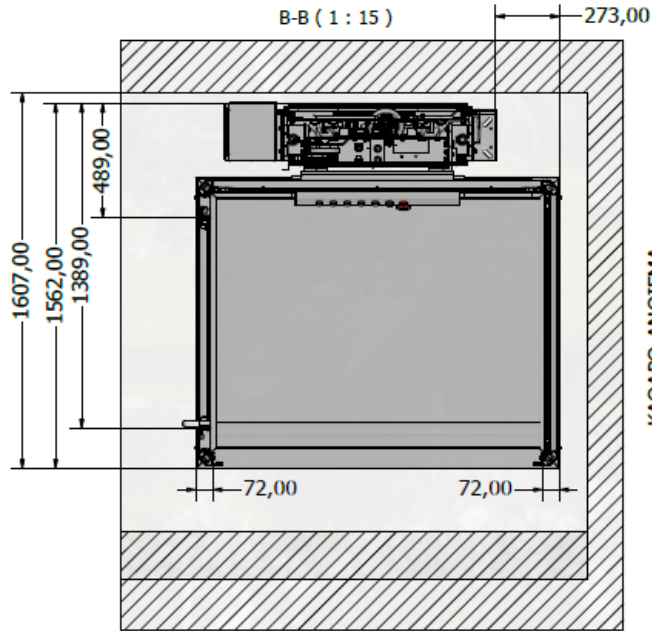

C-C (1 : 11)

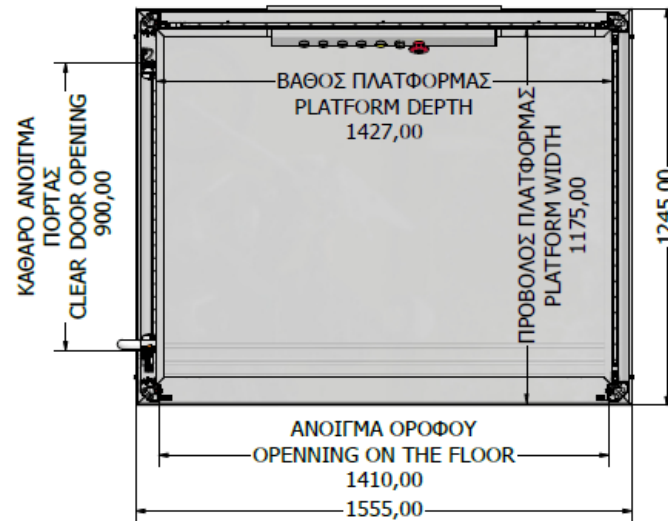

VIEW8 (1 : 23)

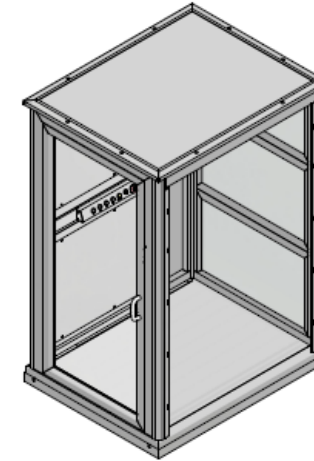

VIEW9 (1 : 23)

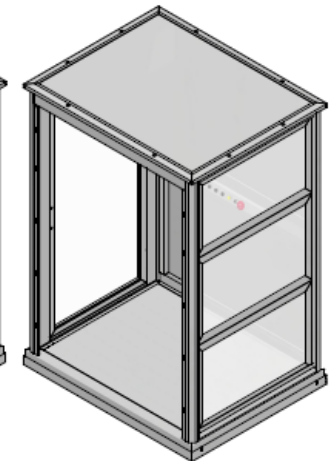

ΕΙΣΟΔΟΣ - ΕΞΟΔΟΣ: ΥΠΟ ΓΩΝΙΑ
ENTRANCE - EXIT: 90°

Type C
1100 x 1400

11.13 Cabin type D | Entrance – Exit: Opposite sides

VIEW3 (1 : 35)

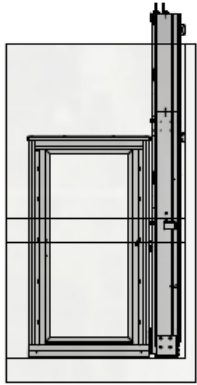

VIEW1 (1 : 35)

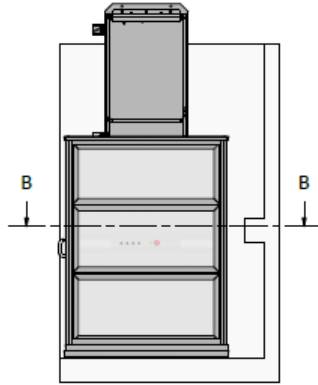

VIEW2 (1 : 35)

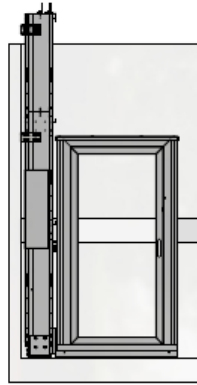

VIEW7 (1 : 20)

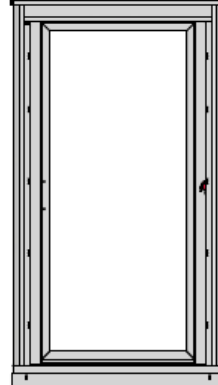

VIEW5 (1 : 20)

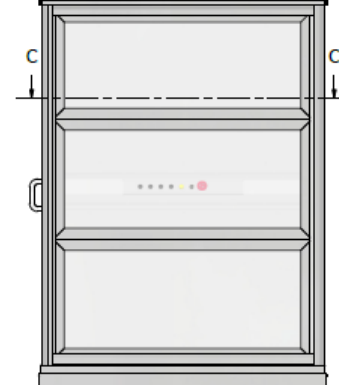

VIEW6 (1 : 20)

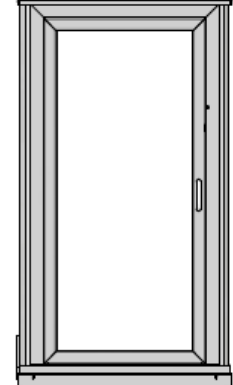

B-B (1 : 18)

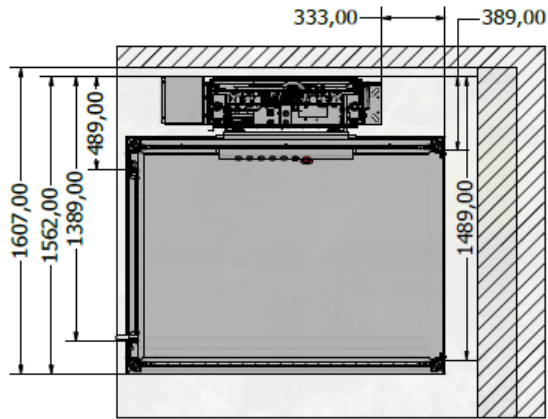

C-C (1 : 11)

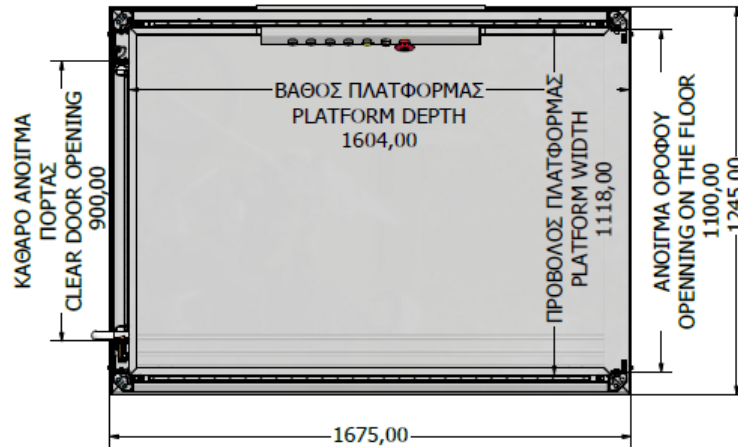

VIEW8 (1 : 23)

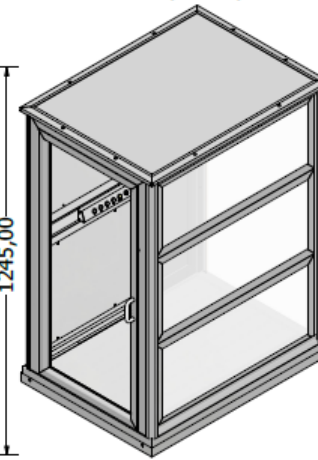

VIEW9 (1 : 23)

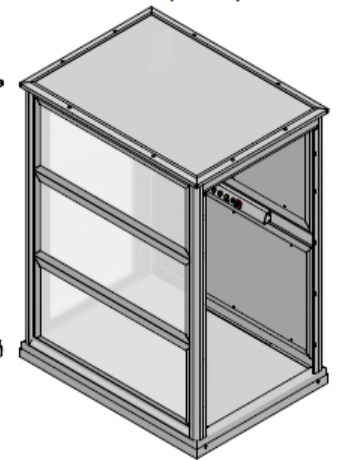

ΕΙΣΟΔΟΣ - ΕΞΟΔΟΣ: ΑΠΕΝΑΝΤΙ
 ENTRANCE - EXIT: OPPOSITE

Type D
 1100 x 1600

11.14 Cabin type D | Entrance – Exit: Same side

VIEW3 (1 : 35)

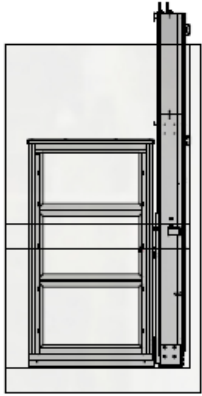

VIEW1 (1 : 35)

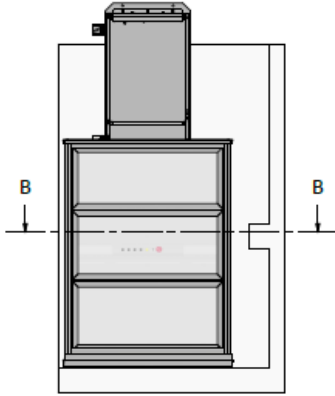

VIEW2 (1 : 35)

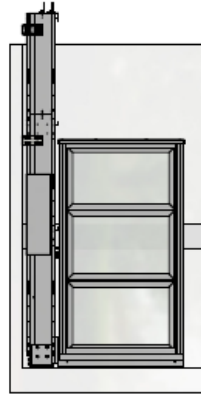

VIEW7 (1 : 20)

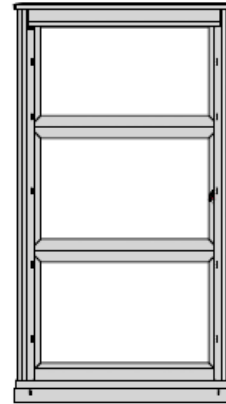

VIEW5 (1 : 20)

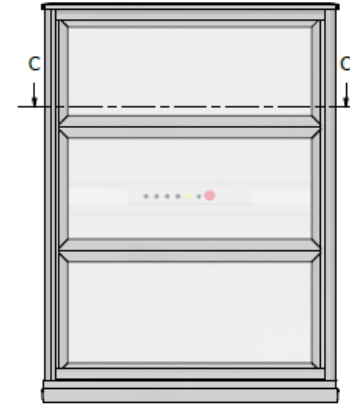

VIEW6 (1 : 20)

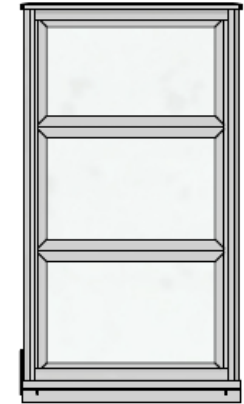

B-B (1 : 18)

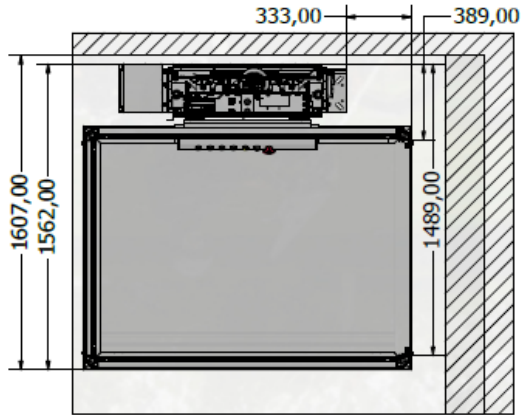

C-C (1 : 11)

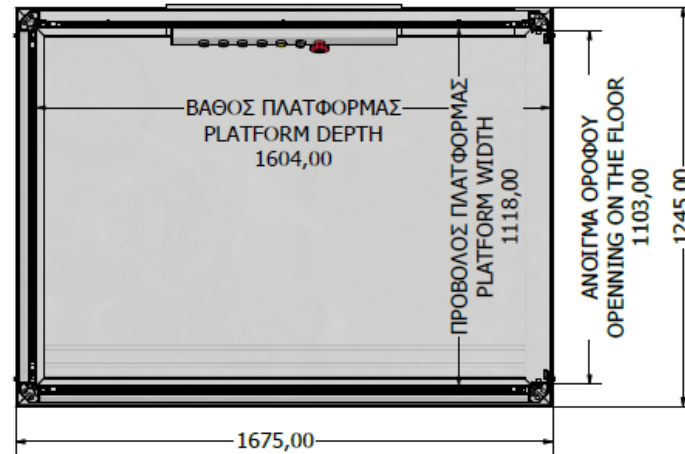

VIEW8 (1 : 23)

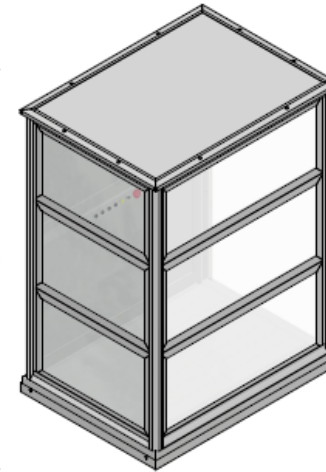

VIEW9 (1 : 23)

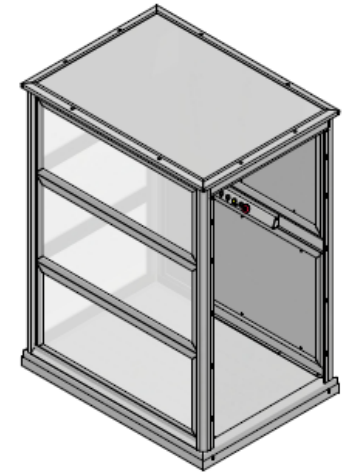

ΕΙΣΟΔΟΣ - ΕΞΟΔΟΣ: ΙΔΙΑ ΠΛΕΥΡΑ
ENTRANCE - EXIT: SAME SIDE

Type D
1100 x 1600

11.15 Cabin type D | Entrance – Exit: Adjacent sides 90°

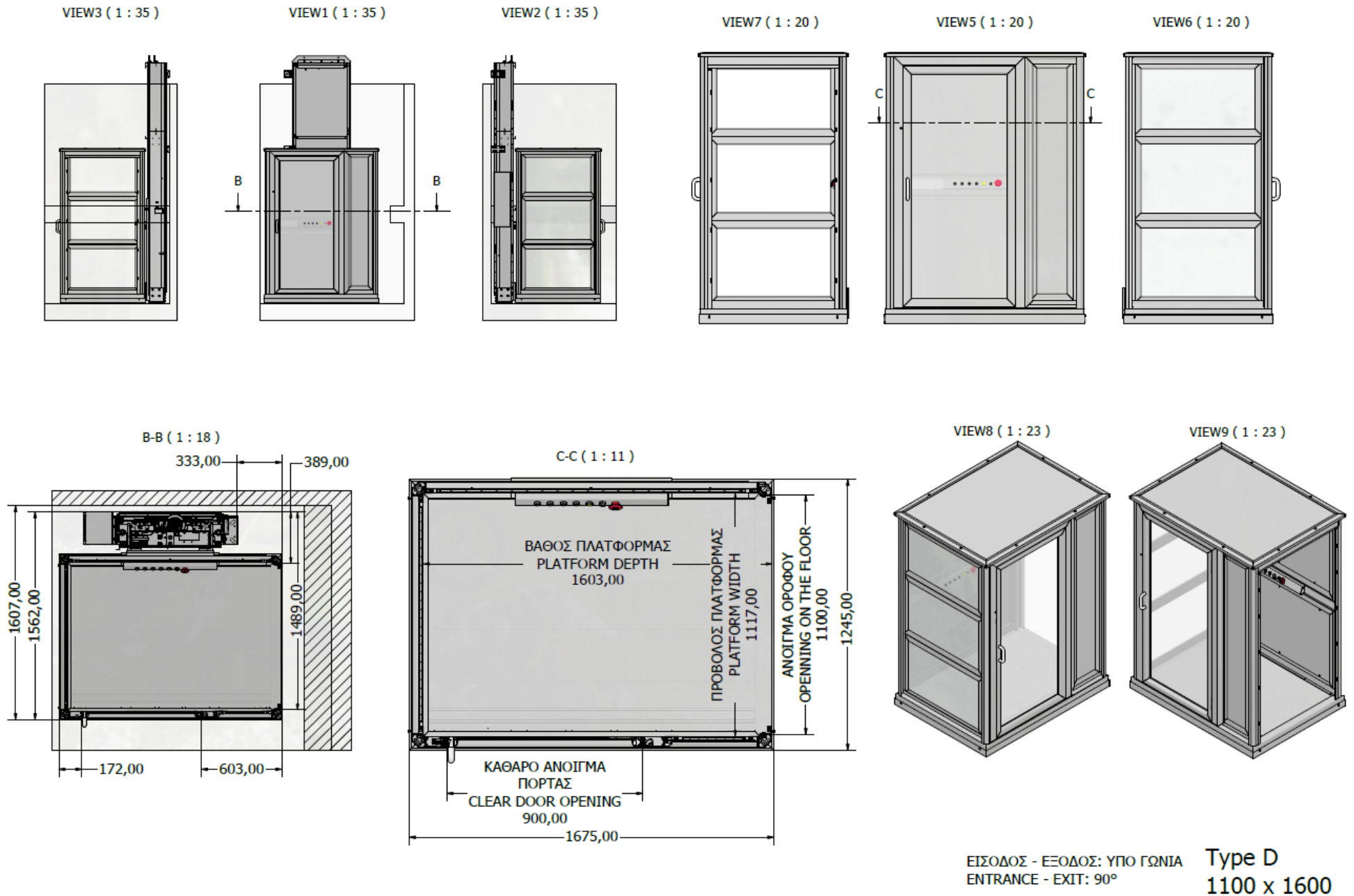

11.16 Cabin type D | Entrance – Exit: Adjacent sides 90°

VIEW3 (1 : 35)



VIEW1 (1 : 35)

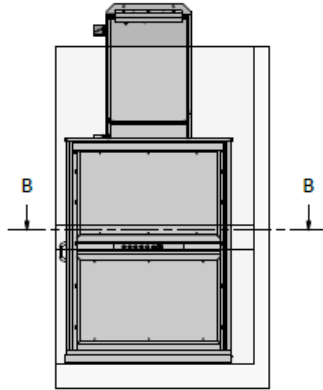

VIEW2 (1 : 35)

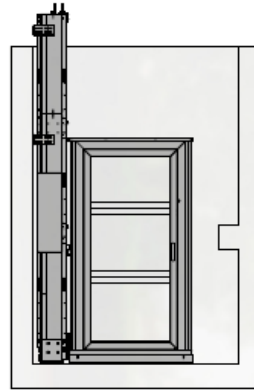

VIEW7 (1 : 20)

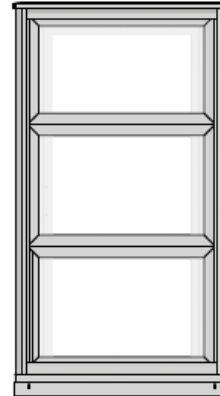

VIEW5 (1 : 20)

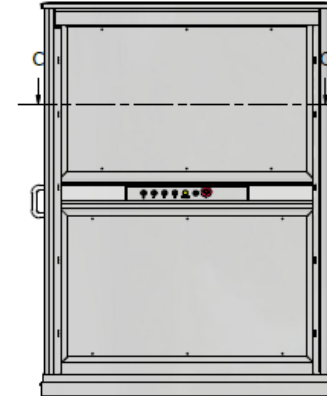

VIEW6 (1 : 20)

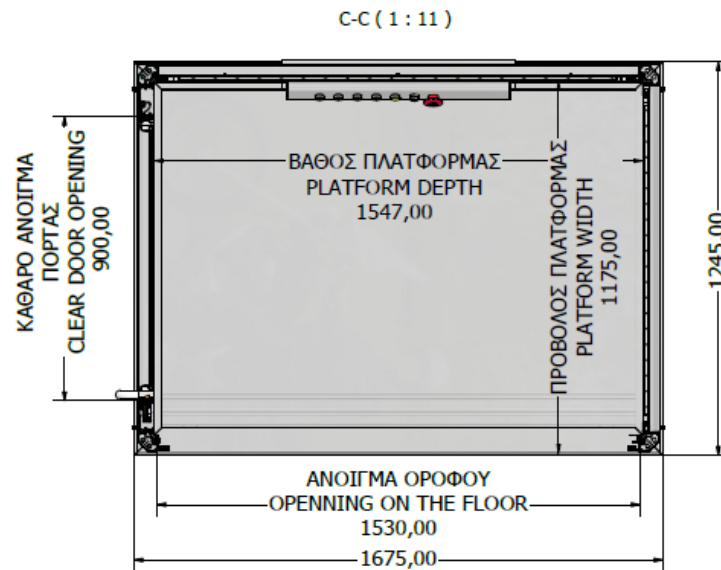
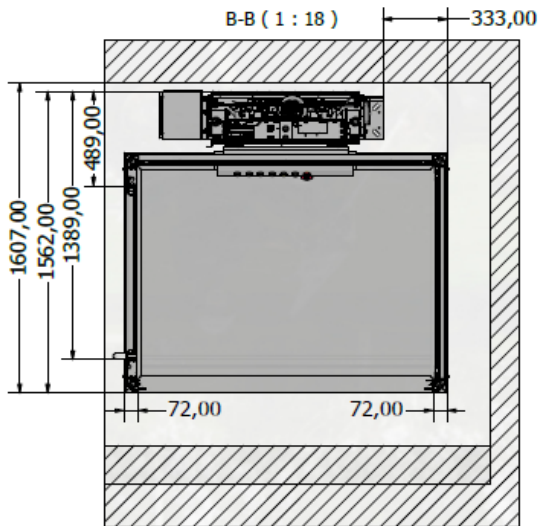
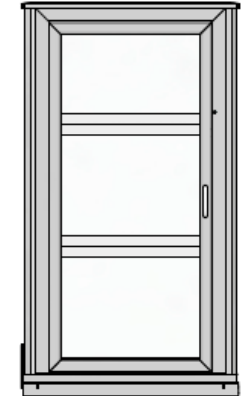

VIEW8 (1 : 23)

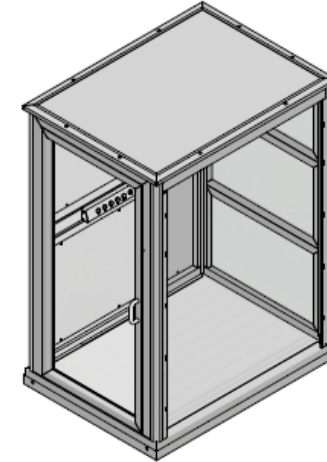

VIEW9 (1 : 23)

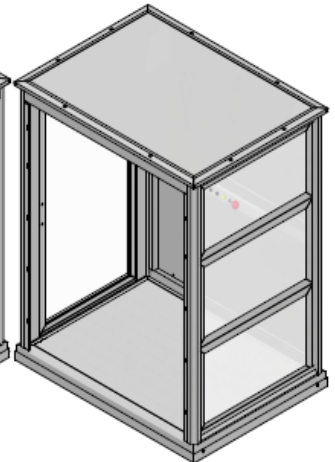

ΕΙΣΟΔΟΣ - ΕΞΟΔΟΣ: ΥΠΟ ΓΩΝΙΑ
ENTRANCE - EXIT: 90°

Type C
1100 x 1600

12. 3D VISUALISATION

12.1 Closed cabin

12.1.1 Entrance – Exit: Opposite sides, 2 stops

In this option the cabin has 2 walls, one side door on the platform and one open side with photocells. The aluminium barrier has 1 door (H 2000mm) at the exit.

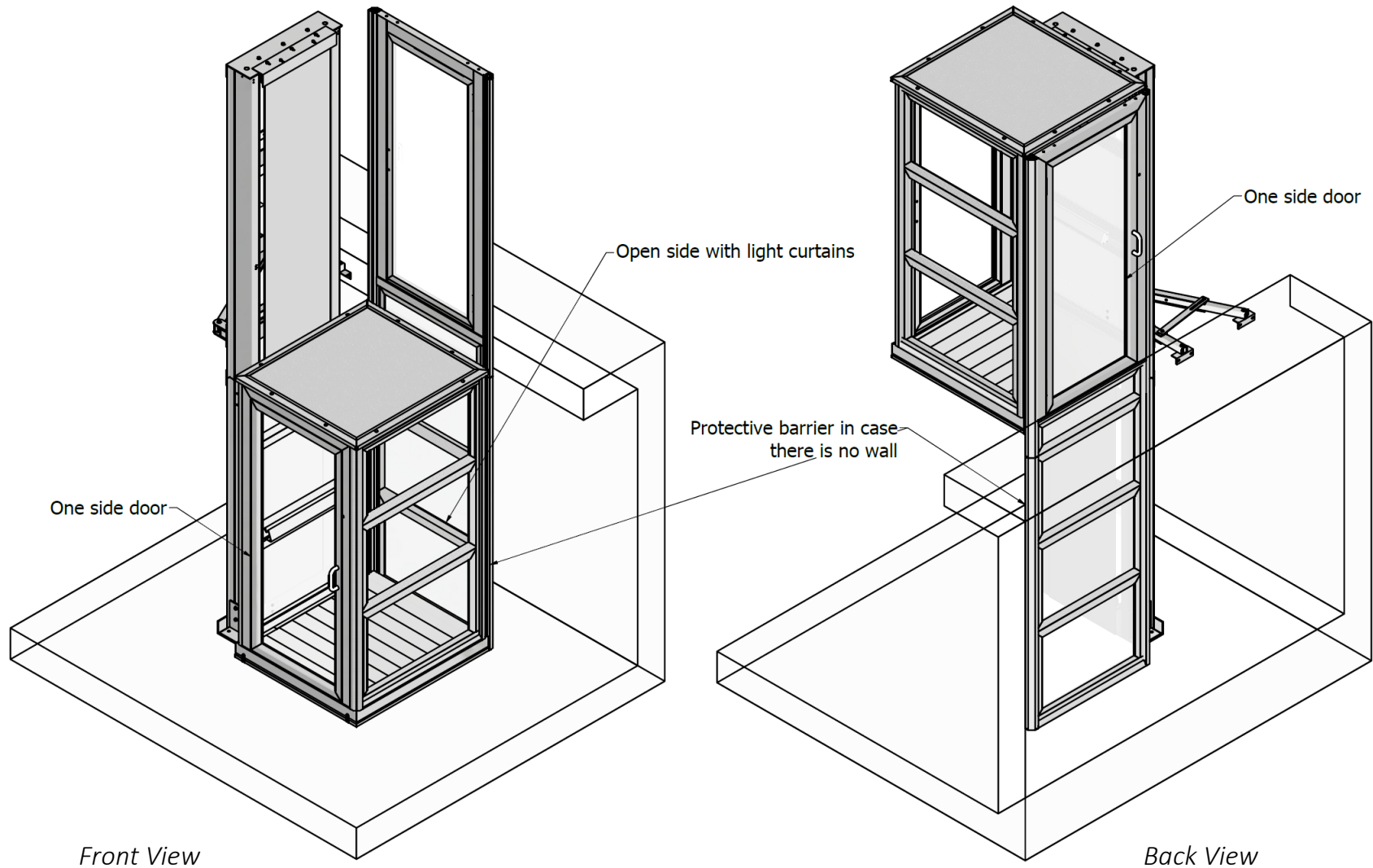

12.1.2 Entrance – Exit: Opposite sides, 3 stops

In case we have more than 2 stops then the wall integrates doors with 2000mm height at each stop.

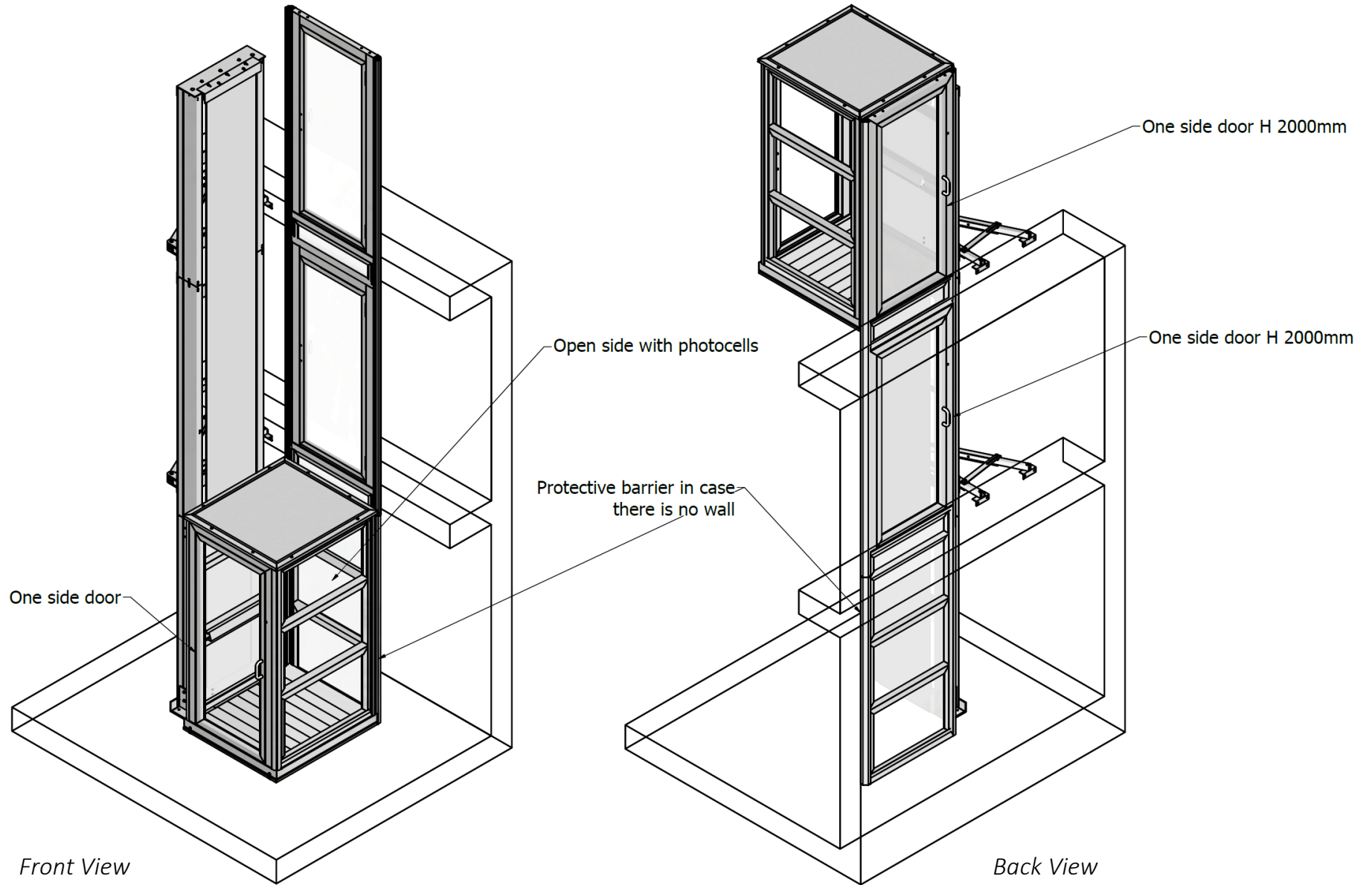

12.1.3 Entrance – Exit: Same sides, 2 stops

In this scenario the cabin has 3 sides closed with panels and one open side that has photocells for safety. The aluminium barrier has both doors fitted. The door in the entrance will have a height of 2000mm and the one in the exit 2000mm.

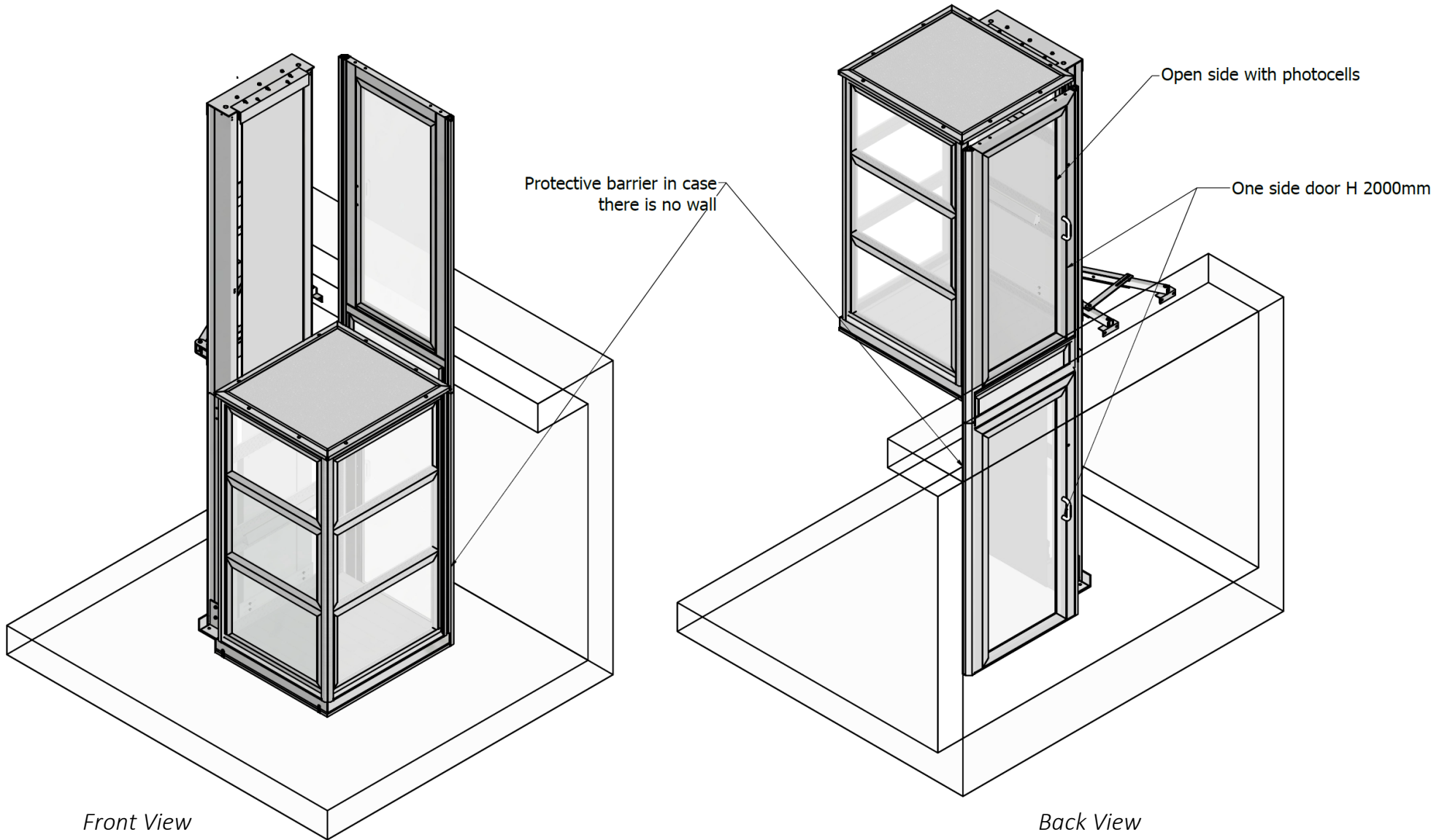

12.1.4 Entrance – Exit: Same side, 3 stops

Similarly in this case we offer a cabin with one open side. The protective barrier in the case integrates 3 doors with 2000mm height on the stops.

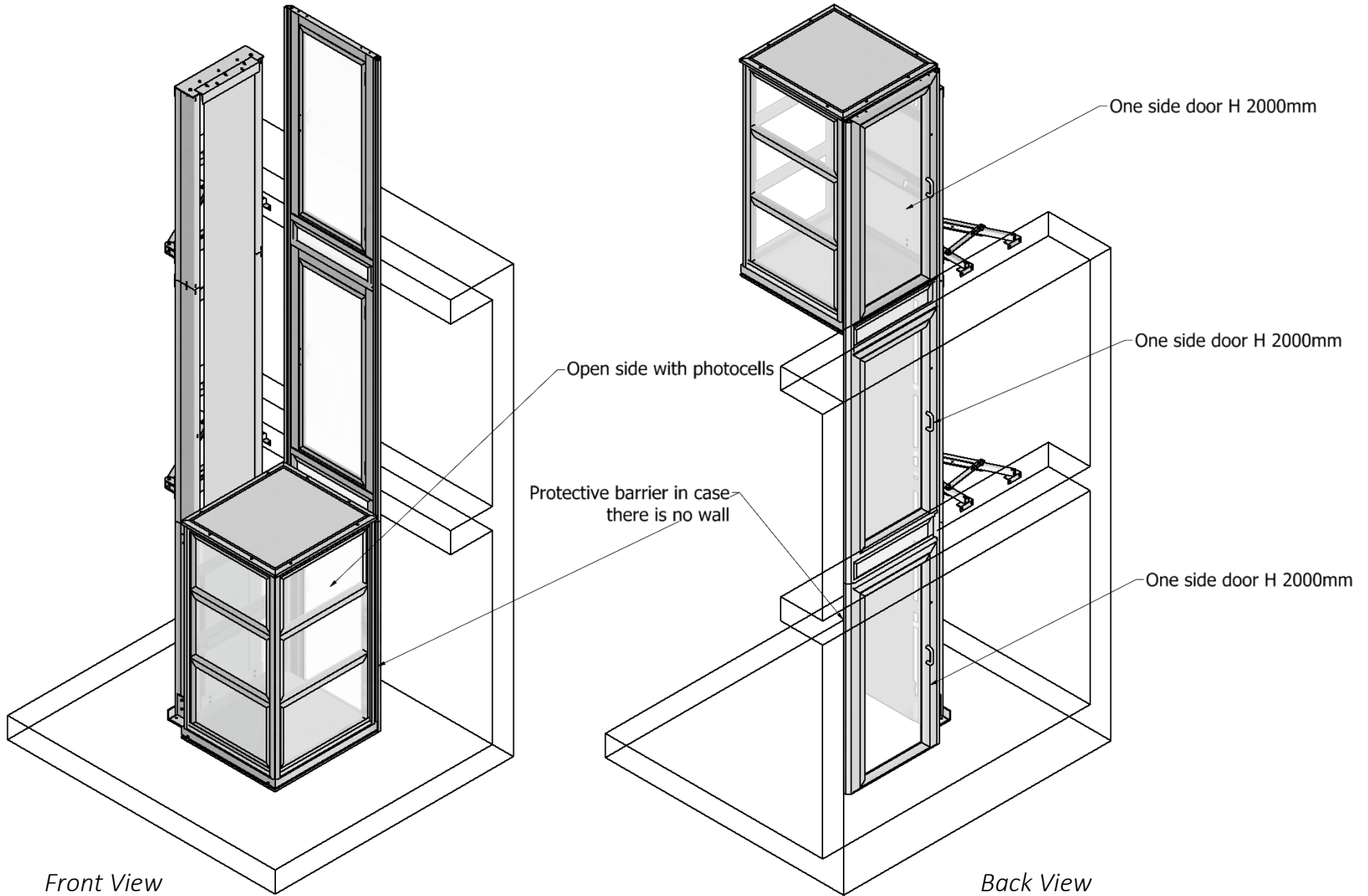

12.1.5 Entrance – Exit: Adjacent sides 90°, 2 stops

In this option the cabin follows the same principle as the entrance exit through. This means the cabin has one side door on the platform, 2 sides covered with panels and one open side with photocells. The aluminium barrier has 1 door (H 2000mm) at the exit.

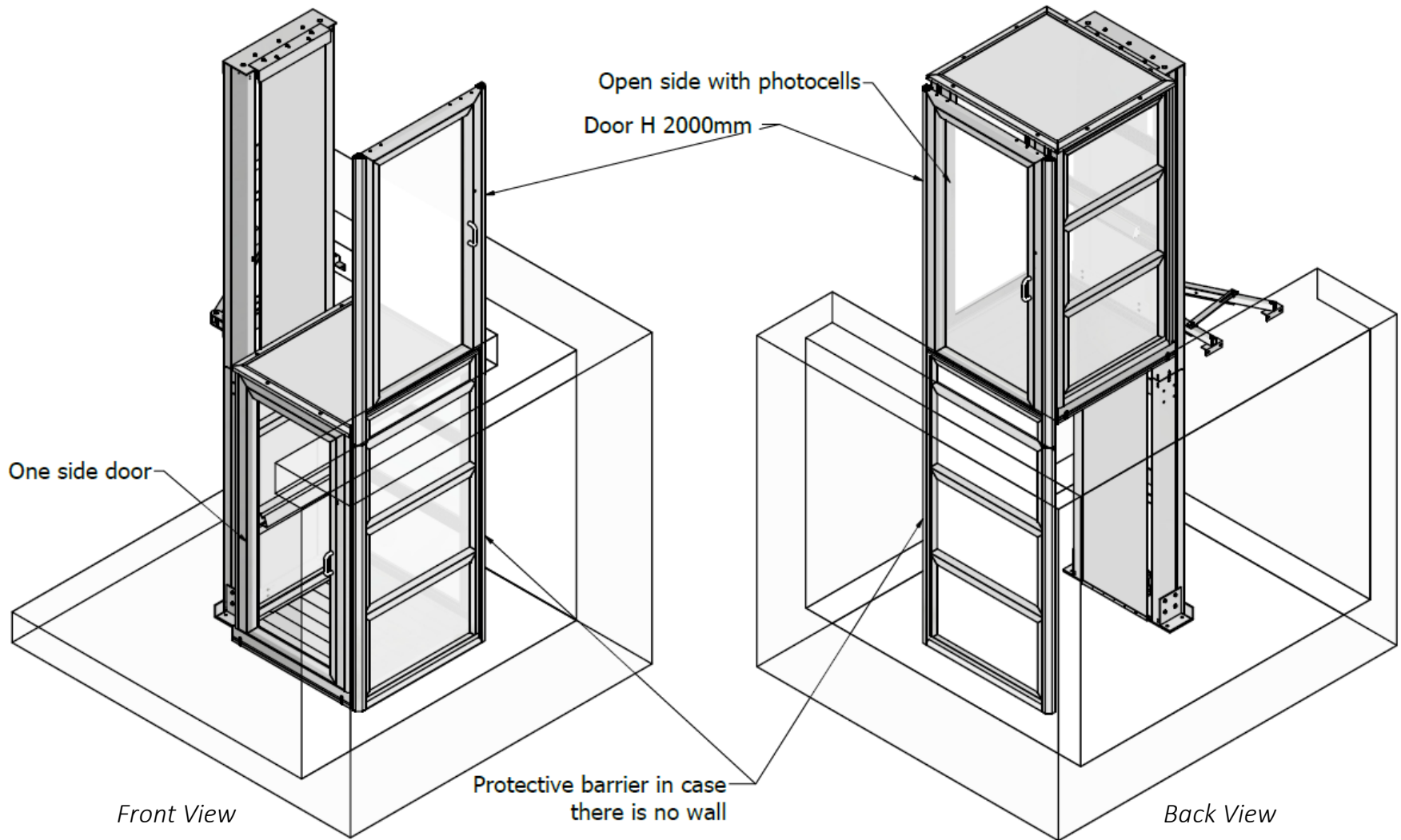

12.2 Open Cabin

12.2.1 Entrance – Exit: Opposite sides, 2 stops

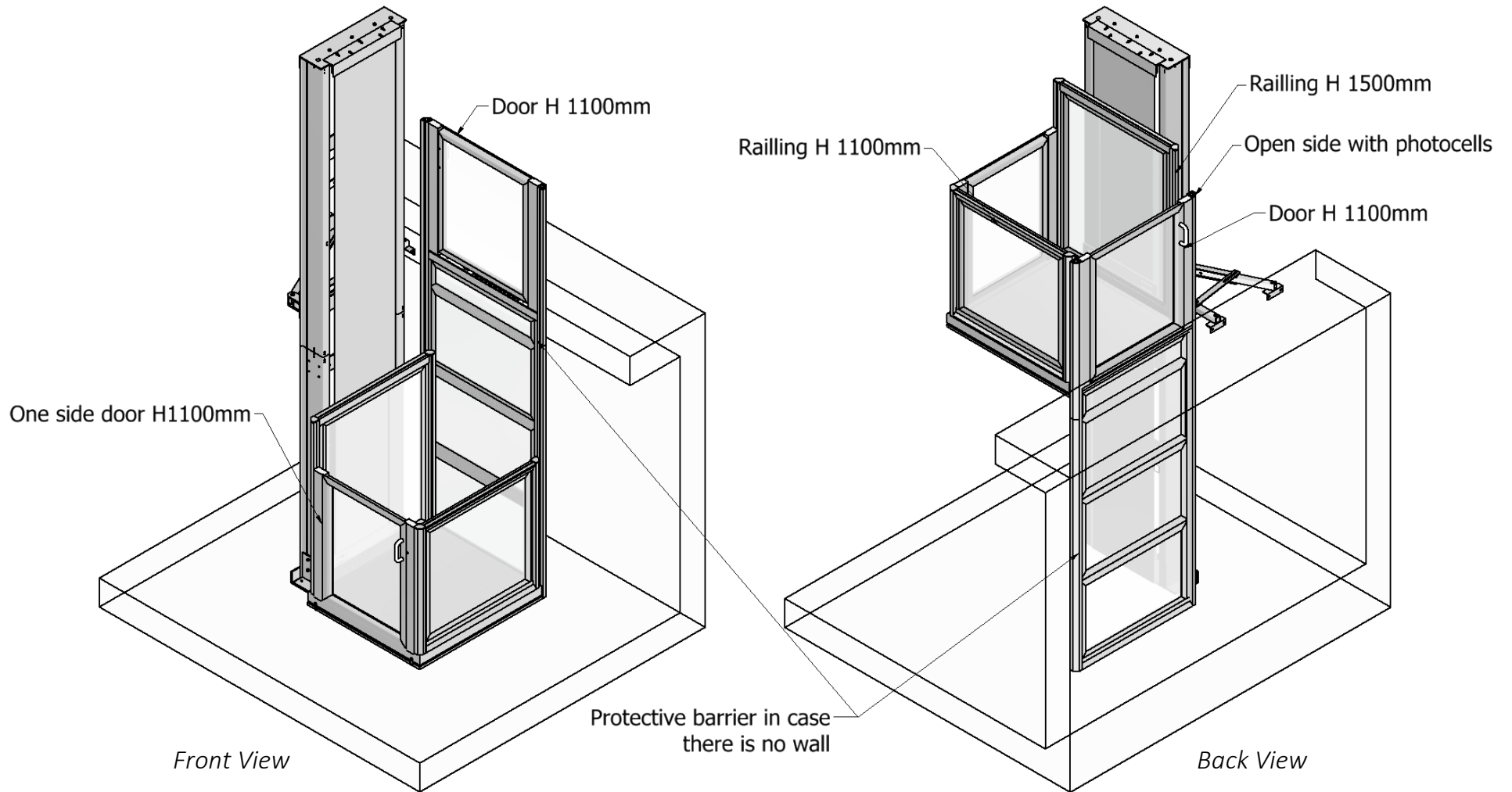

12.2.2 Entrance – Exit: Same side, 2 stops

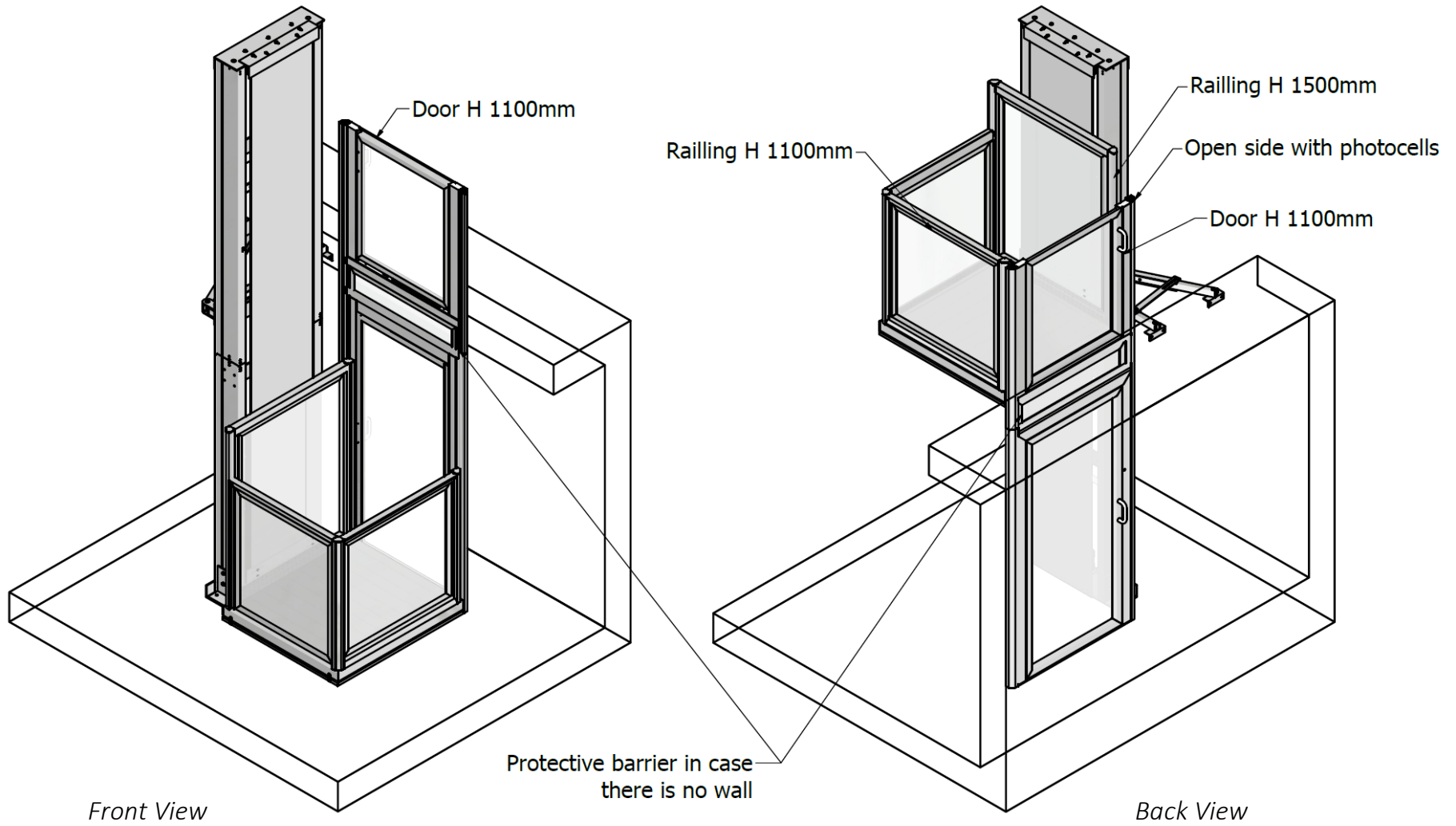

12.2.3 Entrance – Exit: Adjacent sides 90°, 2 stops

